

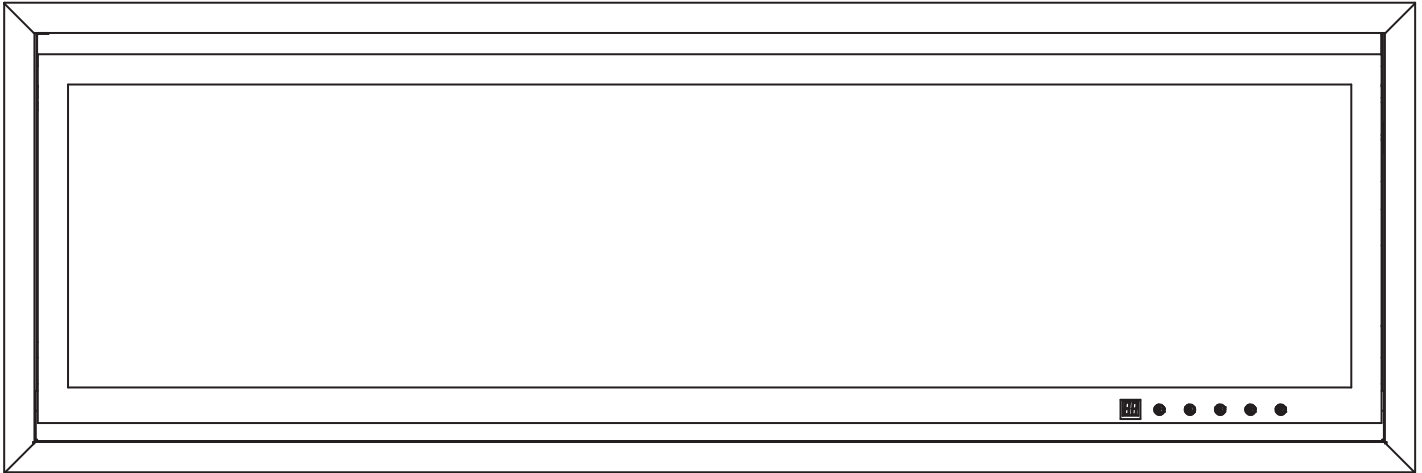

Electric Fireplace

With Mounting Bracket Kit for Adjustable Installation



Owner's Manual

Model Number	Item Number
50	EF10144
60	EF10145
72	EF10146
88	EF10147

 **WARNING-**
Cancer and Reproductive Harm —
www.P65Warnings.ca.go



READ & SAVE THESE INSTRUCTIONS

Carefully read and review before assembling, installing, operating, or maintaining this product. Observe all safety instructions and information.

FAILURE TO FOLLOW WARNINGS & OPERATIONAL INSTRUCTIONS CONTAINED IN THIS MANUAL CAN RESULT IN PROPERTY DAMAGE OR PERSONAL INJURY

****IMPORTANT NOTICE****

For customer service & warranty issues, please contact: customer care@jrhome.com

WARNING

- **THIS APPLIANCE IS HOT WHEN OPERATED AND CAN CAUSE SEVERE BURNS IF CONTACTED.**
- Do not operate appliance before reading and understanding operating instructions. Failure to operate appliance according to operating instructions could cause fire or injury.
- Risk of burns. Power should be turned off and the appliance allowed to cool down before servicing. To disconnect power, turn controls to off, then remove plug from outlet.
- Do not install damaged, incomplete or substitute components.
- Do not burn wood and/or other materials in this appliance.
- Young children should be carefully supervised when they are in the same room as the appliance. Toddlers, young children and others may be susceptible to accidental contact burns. A physical barrier is recommended if there are at risk individuals in the house. To restrict access to an appliance or stove, install an adjustable safety gate to keep toddlers, young children and other at risk individuals out of the room and away from hot surfaces.
- Clothing or other flammable material should not be placed on or near the appliance.
- Due to high temperatures, the appliance should be located out of traffic and away from furniture and draperies.
- Ensure you have incorporated adequate safety measure to protect infants/toddlers from touching hot surfaces.
- Even after the appliance is off, the trim, glass and/or screen will remain hot for an extended period of time.
- Check with your local hearth specialty dealer for safety screens and hearth guards to protect children from hot surfaces. These screens and guards must be securely fastened to the floor.
- Any safety screen or guard removed for servicing must be replaced prior to operating the appliance.
- It is imperative that the control compartments, circulating blower and its passageway in the appliance are kept clean. The appliance should be inspected before use and at least inspected annually by a qualified service person. Frequent cleaning may be required due to excessive lint from carpeting, bedding material, etc. The appliance area must be kept clear and free from combustible materials, gasoline and other flammable vapors and liquids.
- Under no circumstances should this appliance be modified.
- Do not use this appliance if any part has been submerged in water. Immediately call a qualified service technician to inspect the appliance and to replace any part of the control system which has been in contact with water.
- Do not operate the appliance with the glass door removed, cracked or broken. Replacement of the glass should be done by a licensed or qualified service person.
- Do not strike or slam shut the appliance glass door.
- Keep the packaging material out of reach of children and dispose of the material in a safe manner. As with all plastic bags, these are not toys and should be kept away from children and infants.
- Servicing should be done only while the appliance is disconnected from the power supply circuit.
- Always unplug appliance when not in use.
- Do not operate this appliance with a damaged cord or plug after the appliance malfunctions, has been dropped or damaged in any manner. Return appliance to authorized service facility for examination, electrical or mechanical adjustment, or repair.
- Do not use outdoors.
- Do not place appliance where it may fall into a bathtub or other water container.
- Do not run cord under carpeting. Do not cover cord with throw rugs, runners, or the like. Arrange cord away from crowded or high traffic areas and where it will not be tripped over.
- Connect to properly grounded outlets only.
- Do not insert or allow foreign objects to enter any ventilation or exhaust opening as this may cause an electric shock or fire, or damage the appliance.
- To prevent a possible fire, do not block air intakes or exhaust in any manner. Do not use on soft surfaces, like a carpet, where openings may become blocked.
- Always plug appliances directly into a wall outlet/receptacle. Never use an extension cord or relocatable power tap (outlet/power strip).
- Ensure clearances to combustibles are maintained when building a mantel or shelves above the appliance. Elevated temperatures on the wall or in the air above the appliance can cause melting, discoloration or damage to decorations, a T.V. or other electronic components.

Dimensions

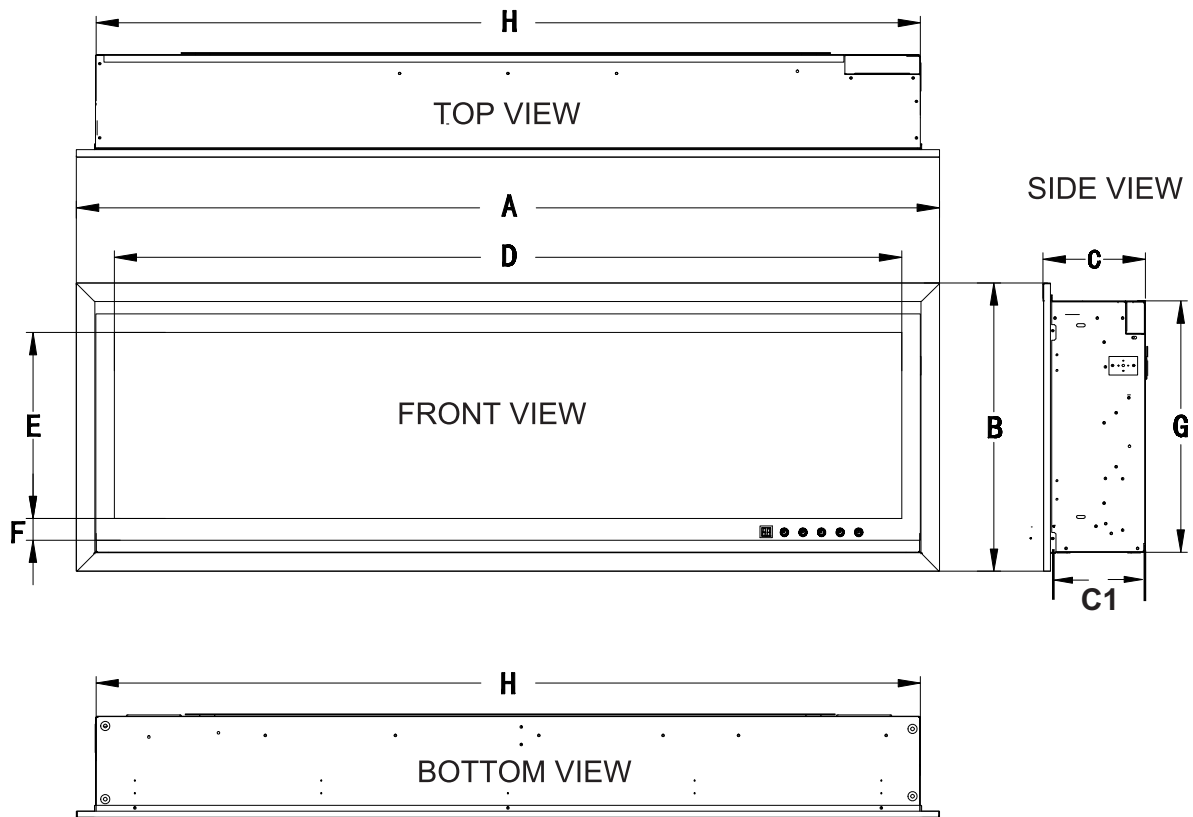

Listing Approvals

This appliance has been tested in accordance with the CSA Standards for fixed and location-dedicated electric room appliances in the United States and Canada. If you need assistance during installation, please contact your local dealer.

NOTE: This appliance must be electrically wired and grounded in accordance with local codes or, in the absence of local codes, with National Electric Code ANSI/NFPA 70-latest edition in the United States or the Canadian Electric Code, CSA C22.2 in Canada.

PRODUCT DIMENSIONS									
Model No.	A	B	C	C1	D	E	F	G	H
EF10144	55" (140CM)	18.3" (47CM)	6.5" (17CM)	6" (15CM)	50" (127CM)	11.8" (30CM)	1.3" (3.3CM)	16" (41CM)	52.4" (133CM)
EF10145	65" (165CM)				60" (152CM)				62.4" (159CM)
EF10146	77" (196CM)				72" (183CM)				74.4" (189CM)
EF10147	93" (236CM)				88" (224CM)				90.4" (230CM)

Model & Item No.	Net Weight	Gross Weight	CARTON DIMENSIONS
EF10144	24.5 KGS	33 KGS	63"W X 11.4"D X 24.8"H
EF10145	28 KGS	38KGS	73"W X 11.4"D X 24.8"H
EF10146	33.5 KGS	45.5 KGS	85"W X 11.4"D X 24.8"H
EF10147	41 KGS	55 KGS	101"W X 11.4"D X 24.8"H

Description	Electric Fireplace
Type	Built-in or Wall Mount
Voltage	120V AC
Watts	MAX 1500W
Amps	15 AMP Grounded Circuit

General Instructions

WARNING

READ THESE INSTRUCTIONS COMPLETELY BEFORE BEGINNING INSTALLATION. FAILURE TO FOLLOW THEM COULD CAUSE AN APPLIANCE MALFUNCTION RESULTING IN SERIOUS INJURY AND/OR PROPERTY DAMAGE.

ALL ELECTRIC APPLIANCES HAVE HOT AND ARCING OR SPARKING PARTS INSIDE. DO NOT USE IT IN AREAS WHERE GASOLINE, PAINT OR FLAMMABLE LIQUIDS ARE PRESENT.

THIS ELECTRIC APPLIANCE IS TESTED AND LISTED FOR USE ONLY WITH THE OPTIONAL ACCESSORIES LISTED IN THESE INSTRUCTIONS. USE OF OPTIONAL ACCESSORIES NOT SPECIFICALLY TESTED FOR THIS ELECTRIC APPLIANCE COULD VOID THE WARRANTY AND/OR RESULT IN A SAFETY HAZARD.

DO NOT OPEN. RISK OF ELECTRIC SHOCK. NO USER-SERVICEABLE PARTS INSIDE.

DO NOT USE DAMAGED ELECTRICAL CORDS.

SERVICING SHOULD BE DONE ONLY WHILE THE APPLIANCE IS DISCONNECTED FROM THE POWER SUPPLY CIRCUIT.

TO PREVENT ELECTRIC SHOCK MATCH THE WIDE BLADE OF PLUG TO WIDE SLOT OF RECEPTACLE AND FULLY INSERT.

1. Prior to plugging your appliance into an electrical outlet, verify that the house circuit breakers for the outlet are on.
2. The appliance may emit a slight, harmless odour when first used. This odour is normal and it is caused by the initial heating of internal appliance elements and will not occur again.
3. If your appliance does not emit heat, consult the operation section of this manual for further information.
4. Use with a CSA or UL certified surge protector.
5. Do not route the power cord directly underneath the appliance.







This electric appliance meets the construction and safety standards of H.U.D. for application in manufactured homes when installed according to these instructions.

As with most electronic devices, your new electric fireplace has been designed to operate at temperatures between 5°C (41°F) and 35° C (95°F). During the colder winter months, allow the fireplace to reach room temperature before turning it on

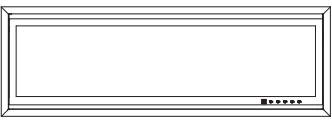
Unpacking and Testing Appliance

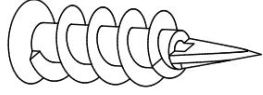
Carefully remove the appliance from the box. Prior to installing the appliance, test to make sure the appliance operates properly by plugging the power supply cord into a conveniently located 120 Volt grounded outlet.

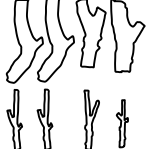
Hardware Parts List

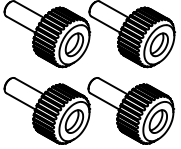
 <p>A- Fireplace</p> <p>EF10144 x1 EF10145 x1 EF10146 x1 EF10147 x1</p>	 <p>B- Mounting Bracket</p> <p>EF10144 x1 EF10145 x1 EF10146 x1 EF10147 x1</p>	 <p>C- Wood Screws</p> <p>EF10144 x19 EF10145 x19 EF10146 x22 EF10147 x22</p>	 <p>D- Drywall Anchors</p> <p>EF10144 x13 EF10145 x13 EF10146 x16 EF10147 x16</p>
 <p>E-Remote Control</p> <p>EF10144 x1 EF10145 x1 EF10146 x1 EF10147 x1</p>	 <p>F- Logs</p> <p>EF10144 x8 EF10145 x8 EF10146 x10 EF10147 x12</p>	 <p>G - Black Crystals</p> <p>EF10144 x2 Bags EF10145 x3 Bags EF10146 x4 Bags EF10147 x 5 Bags</p>	 <p>H-Adjustable Foot</p> <p>EF10144 x4 EF10145 x4 EF10146 x4 EF10147 x4</p>

Download the Apps

Available for Android and iOS, the Smart Life app can be used to control your WiFi-enabled fireplaces.



Smart Life



Available voice control for Alexa and Google. Scan the QR codes bellow.

“Hey Google”



Alexa



more help? <https://www.jrhome.com/app-smart-flame-connect-techsup/>

Locating Appliance

WARNING

DUE TO HIGH TEMPERATURES, THIS ELECTRIC APPLIANCE SHOULD BE LOCATED OUT OF TRAFFIC. KEEP COMBUSTIBLE MATERIALS SUCH AS FURNITURE, PILLOWS, BEDDING, PAPERS, CLOTHES AND CURTAINS AT LEAST 36" (914mm) FROM THE FRONT OF THE APPLIANCE.

NEVER LOCATE THIS ELECTRIC APPLIANCE WHERE IT MAY FALL INTO A BATHTUB OR OTHER WATER CONTAINER.

WEAR SAFETY GLOVES AND SAFETY GLASSES FOR PROTECTION DURING INSTALLATION AND MAINTENANCE.

TO PREVENT CONTACT WITH SAGGING OR LOOSE INSULATION, THE ELECTRIC APPLIANCE MUST NOT BE INSTALLED AGAINST VAPOR BARRIER OR EXPOSED INSULATION. LOCALIZED OVERHEATING COULD OCCUR AND A FIRE COULD RESULT.

DO NOT EXPOSE THE ELECTRIC APPLIANCE TO THE ELEMENTS (SUCH AS RAIN, ETC.)

Grounding Appliance

This appliance is for use on 120 Volts. The cord has a plug as shown in (A).

To disconnect appliance, turn controls to off, then remove plug from outlet.

GROUNDING METHODS

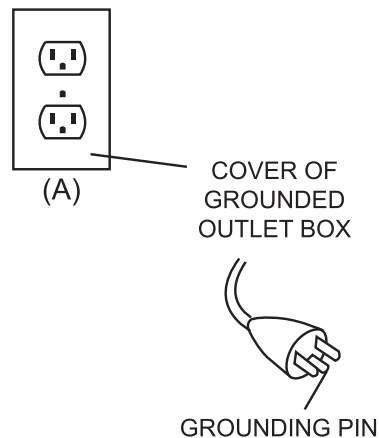

Installation

WARNING

RISK OF FIRE! THE POWER CORD MUST NOT BE PINCHED AGAINST A SHARP EDGE. SECURE CORD TO AVOID TRIPPING OR SNAGGING TO REDUCE THE RISK OF FIRE, ELECTRIC SHOCK OR PERSONAL INJURY. DO NOT RUN CORD UNDER CARPETING. DO NOT COVER CORD WITH THROW RUGS, RUNNERS OR THE LIKE. ARRANGE CORD AWAY FROM TRAFFIC AREAS AND WHERE IT WILL NOT BE TRIPPED OVER.

RISK OF FIRE! TO PREVENT A POSSIBLE FIRE, DO NOT BLOCK AIR INTAKE OR EXHAUST IN ANY MANNER. DO NOT USE ON SOFT SURFACES WHERE OPENINGS MAY BECOME BLOCKED.

RISK OF FIRE! DO NOT BLOW OR PLACE INSULATION AGAINST THE APPLIANCE.

THIS ELECTRIC APPLIANCE IS TESTED AND LISTED FOR USE ONLY WITH THE APPROVED OPTIONAL ACCESSORIES. USE OF OPTIONAL ACCESSORIES NOT SPECIFICALLY TESTED FOR THIS ELECTRIC APPLIANCE COULD VOID THE WARRANTY AND/OR RESULT IN A SAFETY HAZARD.

IF THE INFORMATION IN THESE INSTRUCTIONS IS NOT FOLLOWED EXACTLY, A FIRE OR EXPLOSION MAY RESULT CAUSING PROPERTY DAMAGE, PERSONAL INJURY OR DEATH. DO NOT STORE OR USE GASOLINE OR OTHER FLAMMABLE VAPORS IN THE VICINITY OF THIS OR ANY OTHER APPLIANCE.

THIS APPLIANCE IS HEAVY. IT IS HIGHLY RECOMMENDED THAT TWO PEOPLE INSTALL THIS APPLIANCE.

HEATER VENTS ON THE ELECTRIC APPLIANCE CANNOT, IN ANY WAY, BE COVERED AS IT MAY CREATE A FIRE HAZARD.

DO NOT RUN THE POWER CORD HORIZONTALLY, DIRECTLY BELOW THE APPLIANCE.

Your JR 50D/60D/72D/88D unit is a wall-mounted appliance. Select a suitable location that is not susceptible to moisture and is away from drapes, furniture and high traffic areas.

NOTE: Follow all National and local electrical codes.

Minimum Clearance to Combustibles

Measurements are taken from the glass front

Bottom	0"	Top	0"
Sides	0"	Top	0"
Back	0"		

Minimum Mantel Clearances

WARNING

WHEN USING PAINT OR LACQUER TO FINISH THE MANTEL, THE PAINT OR LACQUER MUST BE HEAT RESISTANT TO PREVENT DISCOLOURATION.

Adjustable Mounting Brackets and Installation Options

NOTE: It is recommended that the walls for the appliance enclosure be finished (ie. drywall) to avoid exposed insulation or vapour barriers coming in contact with the appliance. This will ensure clearance to combustibles is maintained.

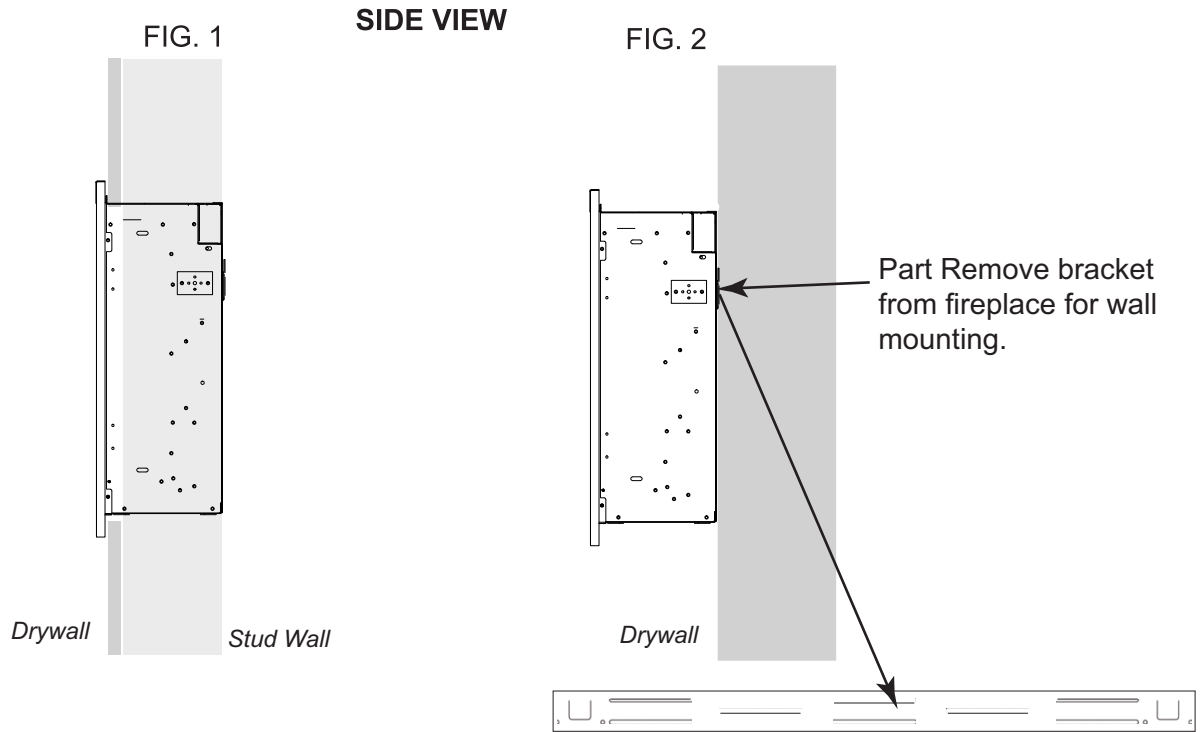

OPTION 1

Full Recess:
For installation instructions refer to Page 11

OPTION 2

Wall Hanging:
For installation instructions refer to Page 9

FRONT VIEW



-Easy to install
-Space saving

-Environment friendly
-Elegant design

Option 1: Hanging the Appliance on the Wall

Due to the many different materials used on different walls, it is highly recommended that you consult your local builder before you install this appliance on the wall.

1. Select a location that is not prone to moisture and is located at least 36" (914mm) away from combustible materials such as curtain drapes, furniture, bedding, paper, etc.
2. Have two people hold the appliance against the wall to determine the final location.
3. Remove the bracket from the back of the unit by removing the two screws, refer to Figure 4.
4. Mark out location, then mount the bracket onto the wall using the 8 supplied screws. This bracket **MUST** have the hooks facing upward and be level.

NOTE: It is strongly recommended that the mounting bracket be screwed into the wall studs where possible. If the wall studs cannot be used, ensure that the supplied plastic anchors are used to affix the bracket to the wall and the bracket is adequately secured

5. With the wall mounting bracket installed have two people lift the appliance up and insert the two hooks on the bracket into the two slots on the back of the appliance.
6. Check the appliance for stability ensuring that the bracket will not pull free from the wall.

FIGURE 4

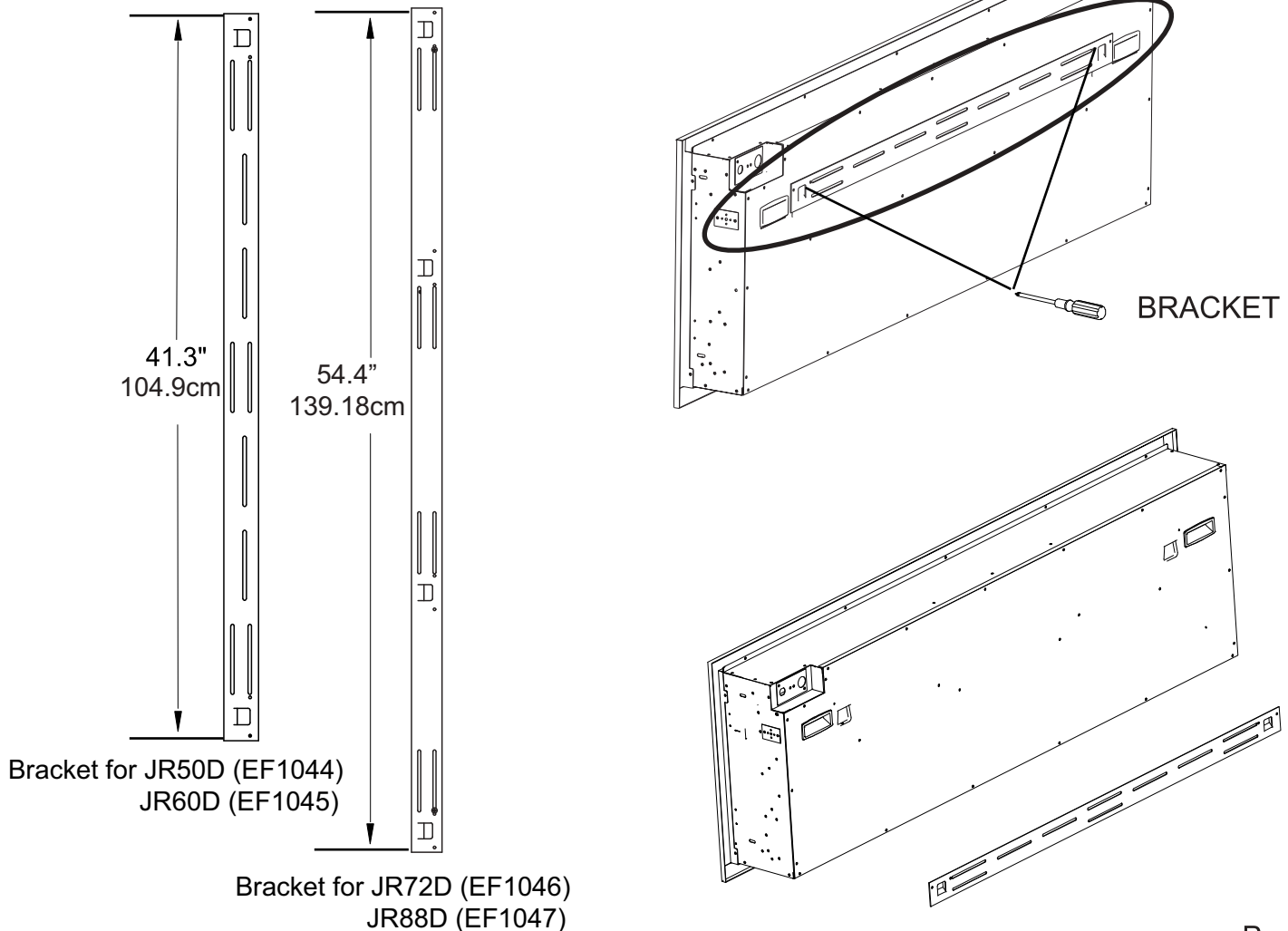

Option 2: Recessing the Appliance Flush into the Wall

Due to the many different finish materials used on walls, it is highly recommended that you consult your local builder before you install this appliance in the wall.

Select a location that is not prone to moisture and is located at least 36" (914mm) away from combustible materials such as curtain drapes, furniture, bedding, paper etc.

1. Measure the appliance and create a rough in with electrical.
2. Hold the appliance up to ensure it will fit into the framing.
3. Remove the front glass (refer to Pages 14 for instructions).
4. Adjust the 4 oblong installation holes on both sides in the upper and lower corner of the firebox. Use the wood screws to mount and secure the firebox to the wood frame.

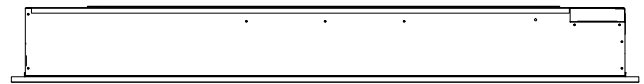
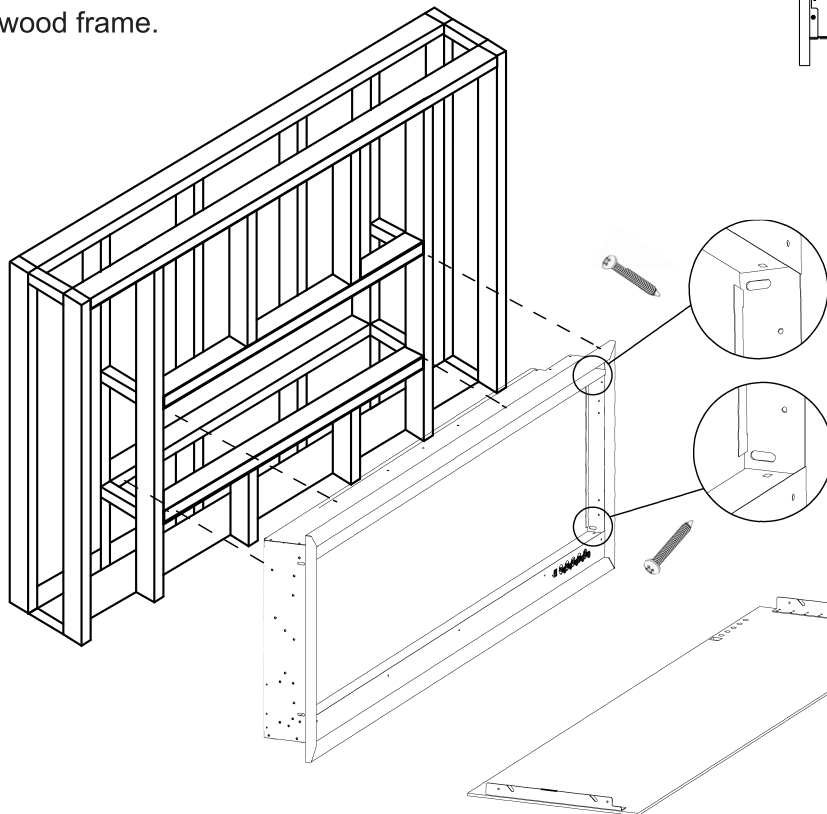

TOP VIEW

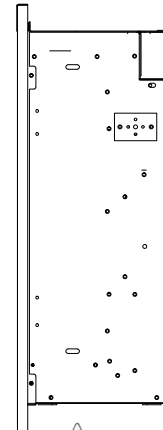

SIDE VIEW

Install 2 screws

NOTE: The slim design of our units allow them to fit in 2x4 framing up to 2x8 framing.



FRONT VIEW

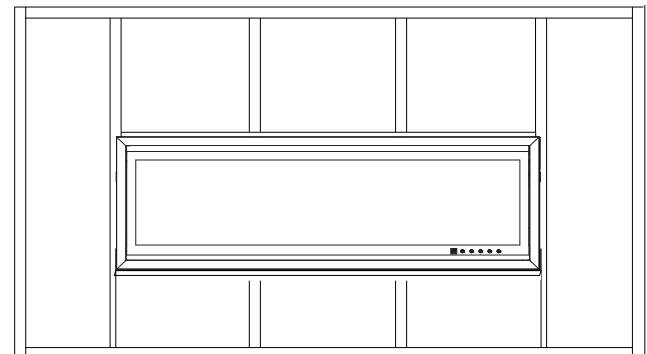

Option 3: Floor or Tabletop Usage

You may install the optional feet (Part H x 4) to enjoy the fireplace as a freestanding unit suitable for tabletop or floor level usage.

NOTE: Insure all logs, rocks or other media has been removed before proceeding.

1. Turn the fireplace upside down.
2. Screw in the 4 adjustable feet.
3. Place fireplace on desired surface.

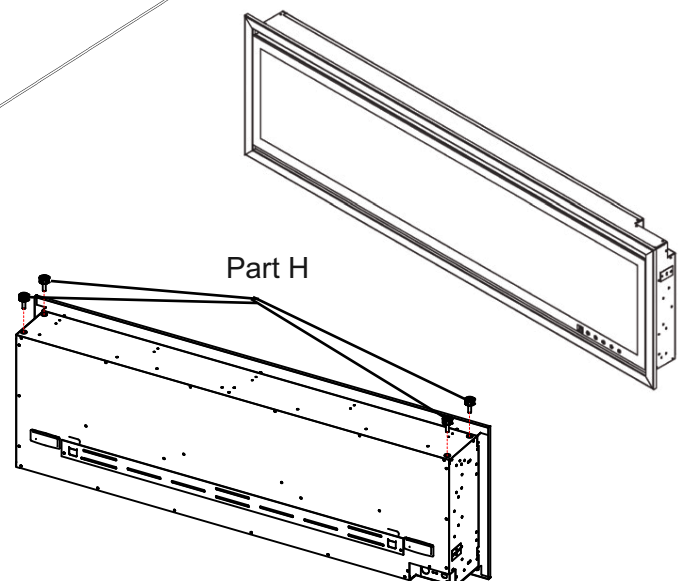

Minimum Clearance to Combustibles

Measurements are taken from the glass front	
Sides, back and top	0"

Framing for Recessed in Wall Installation Options

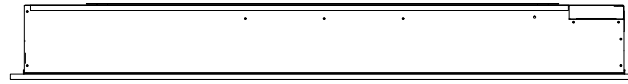

TOP VIEW

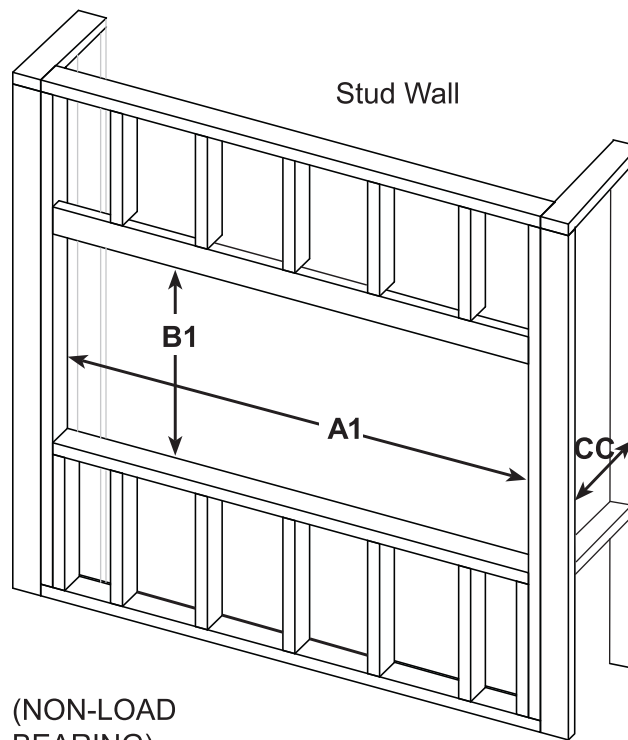

(NON-LOAD BEARING)

Item No.	A	B	C Firebox with trim width	A1 (opening)	B1 (opening)	CC Firebox without trim width + 0.5" opening
EF10144	55"(140cm)	18.3"(47cm)	6.5"(17cm)	53.4"(136cm)	17"(43cm)	6.5"(17cm)
EF10145	65"(165cm)			63.4"(161cm)		
EF10146	77"(196cm)			75.4"(192cm)		
EF10147	93"(236cm)			91.4"(232cm)		

NOTE to installer: A1, B1, and CC are the suggested opening dimensions for installing the firebox into the frame wall. Dimensions are subject to the constructor's final confirmation.

Hard Wiring Installation



TURN OFF THE APPLIANCE COMPLETELY AND LET COOL BEFORE SERVICING. ONLY A QUALIFIED SERVICE PERSON SHOULD SERVICE AND REPAIR THIS ELECTRIC APPLIANCE.

HARD WIRING CONNECTION

If it is necessary to hard wire this appliance, a qualified electrician must remove the cord connection, and wire the appliance directly to the house hold wiring. This appliance must be electrically connected and grounded in accordance with local codes.

1. Remove the cover plate from the left side of the appliance. Remove the two screws, as shown in FIGURE 1. Unscrew and remove power cord.

FIGURE 1

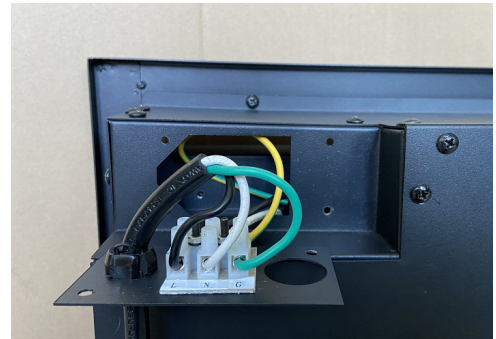
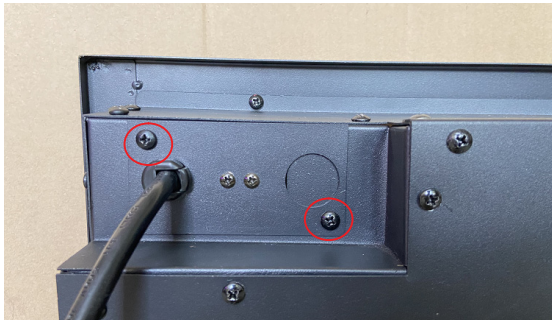

2. Attach the wiring to the wire connector. Please make sure the live wire (Black) goes into the "L", the neutral wire (White) goes into the "N" and the ground wire (Green) goes into the "G".

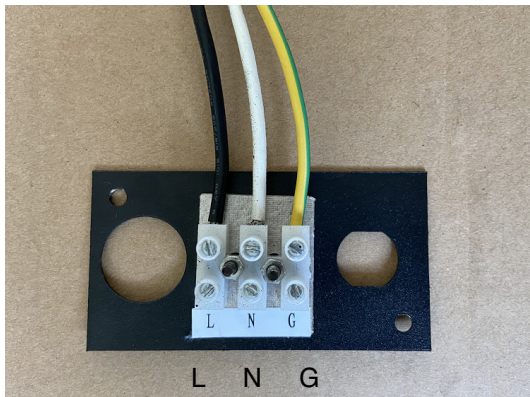

3. Replace the plate and reattach.

NOTE: Leave enough wire so that the appliance can be removed from the enclosure without disconnecting the power supply.

Wall Thermostat Installation



TURN OFF THE APPLIANCE COMPLETELY AND LET COOL BEFORE SERVICING. ONLY A QUALIFIED SERVICE PERSON SHOULD SERVICE AND REPAIR THIS ELECTRIC APPLIANCE.

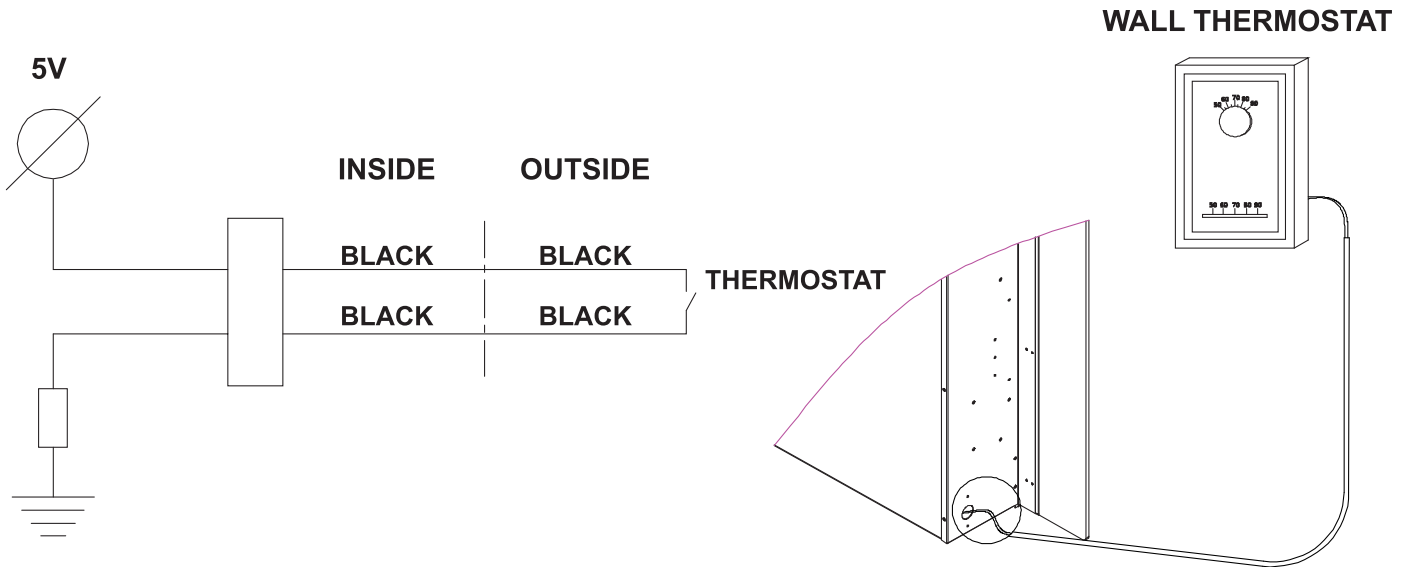

NOTE: Wire the wall thermostat prior to installing the fireplace

Wall Thermostat Wiring (24AWG)

1. Turn off circuit breaker.
2. Remove cover plate located on the left side of the appliance.
3. Pull the wire out and cut the inside thermostat. Connect the wires to the wall thermostat as shown below. Follow instructions provided with wall switch kit.



Front Glass Removal

1. Remove 4 screws on both sides. Remove front glass and place it in a secure location
2. Place the glass safely aside on a flat, smooth surface.

FIGURE 4

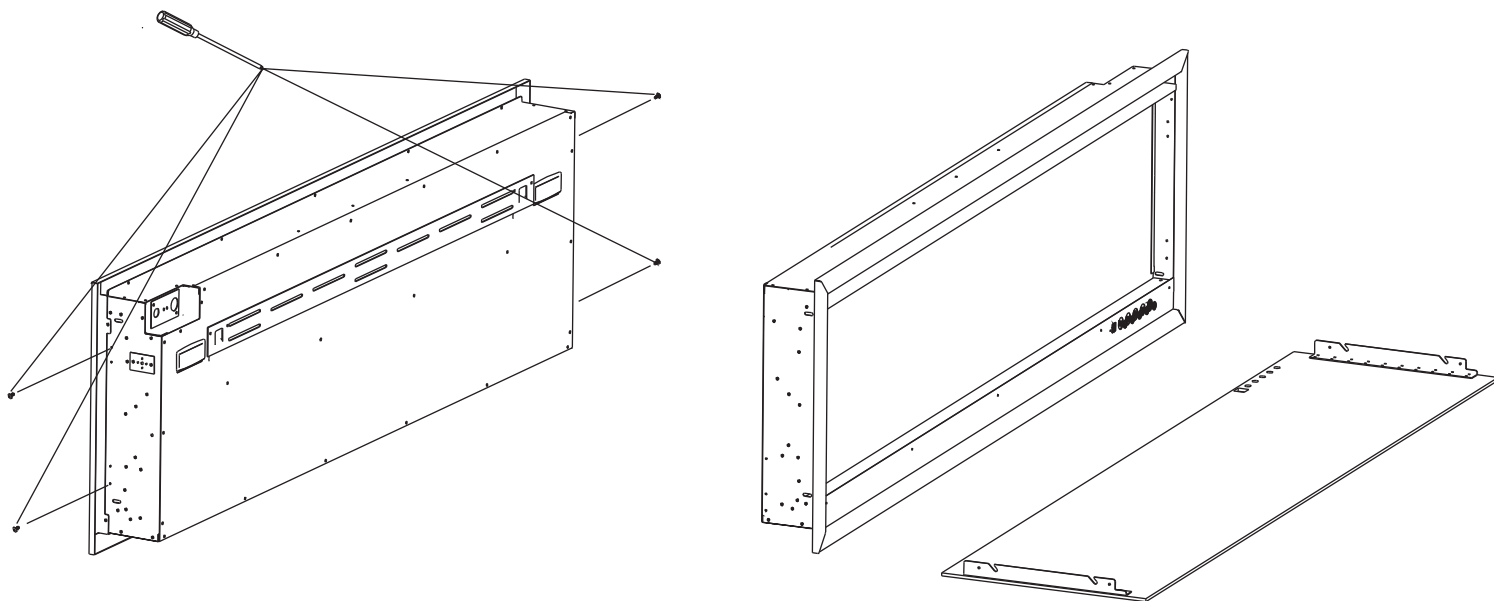

Crystal Embers and Wood Logs Installation

The glass front must be removed and the appliance must be secured in its final location before the crystal embers are installed.

1. Complete steps 1-2 in the “ Front Glass Removal” instructions.
2. Take out the front glass, unload/load the crystal and media onto the ember bed.
3. Replace front glass.

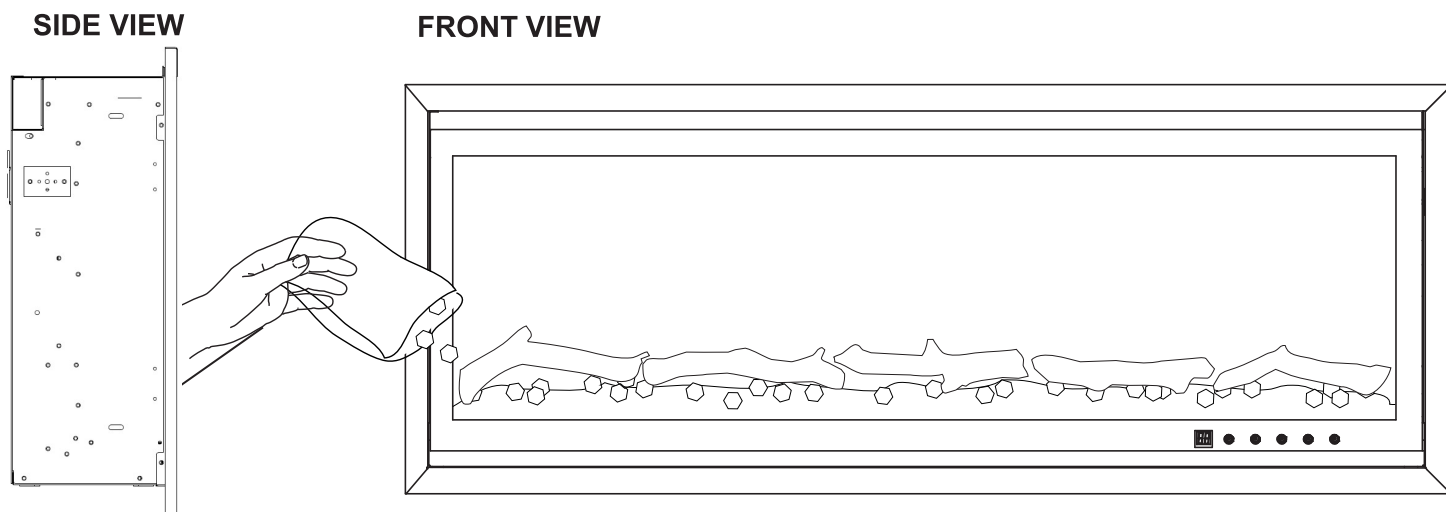

Operating Instructions



WHILE THE APPLIANCE IS OPERATING DO NOT REMOVE THE GLASS PANEL. THIS WILL CAUSE THE REMOTE CONTROL TO DISFUNCTION.

Once the appliance has been plugged into a grounded electrical outlet, it is ready to operate.

NOTE: Ensure the house circuit breakers for the power supply are turned on. In the event of a power failure, the appliance will lose its memory function and will reset to factory mode when the power returns.

Main Power Switch









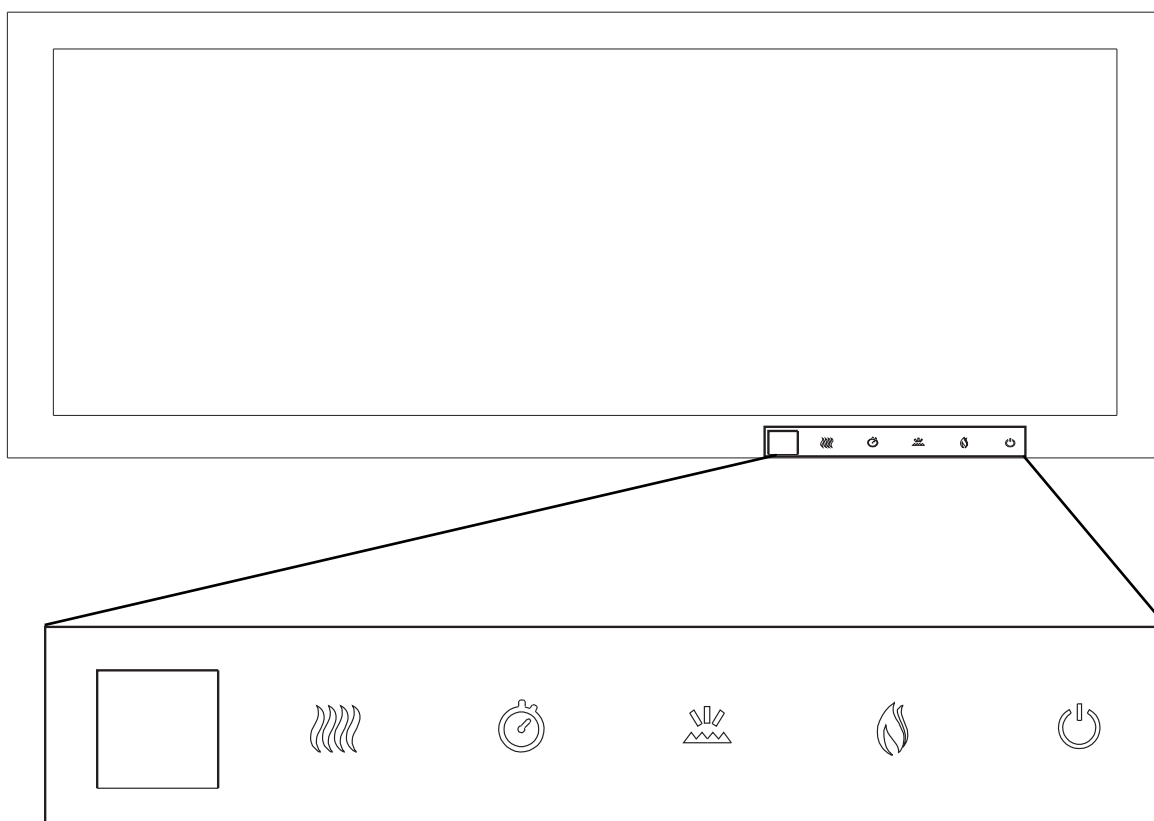



























To turn unit power on:

1. Plug in power cord. If hard wired, just turn on the power switch on the unit.
2. Verify the power is turned on when two ring tones are initiated.





























Operating with Touch Panel

The unit can be controlled by either the touch panel controls which are located on the lower right side of the front glass or the remote control.



FUNCTION	ICON	DISPLAY		OPERATION DETAILS
Power		ON		Turn on the fireplace main power
		OF		Turn off the fireplace main power
Flame		F0		RGB flame off
		F1		Red flame
		F2		Orange flame
		F3		Red-Orange flame
		F4		Yellow flame
		F5		Golden flame
		F6		Green flame
		F7		Forest green flame
		F8		Yellow- Green flame
		F9		Blue flame
		FA		Cyan flame
		Fb		Sea Blue flame
		FC		Light Pink flame
		Fd		Pink flame
		FE		Bright Pink flame
		FF		Purple flame
Ember bed		E0		Ember bed light off
		E1		Red
		E2		Red- Orange
		E3		Light Orange
		E4		Lime
		E5		Green
		E6		Orange
		E7		Blue
		E8		Cyan
		E9		Sea Blue
		EA		Light Purple
		Eb		Purple
		EC		Pink
		Ed		Lavender
EE		Color- rotate		
EF		Rainbow		

Operating with Touch Panel

FUNCTION	ICON	DISPLAY		OPERATION DETAILS
Timer		30		30 minutes
		1H		1 hour
		2H		2 hours
		3H		3 hours
		4H		4 hours
		5H		5 hours
		6H		6 hours
		7H		7 hours
		8H		8 hours
		00		OFF
Heater Temperature		C		Setting to Celsius degree
		16		16 Celsius degrees
		19		19 Celsius degrees
		21		21 Celsius degrees
		23		23 Celsius degrees
		25		25 Celsius degrees
		27		27 Celsius degrees
		30		30 Celsius degrees
		F		Setting to Fahrenheit degree
		61		61 Fahrenheit degrees
		66		66 Fahrenheit degrees
		70		70 Fahrenheit degrees
		73		73 Fahrenheit degrees
		77		77 Fahrenheit degrees
		80		80 Fahrenheit degrees
		86		86 Fahrenheit degree
H0		Heater and blower off		

NOTE: The touch panel buttons will glow when pressed. The light fades in 5 seconds after pressing.

WiFi APP Installation Procedure



Available for Android and iOS, the Smart Life app can be used to control your WiFi-enabled fireplaces. After installing the app follow these steps:

1. Create an Account

Create a profile to use the Smart Life App, and connect your fireplace for convenient control: Ensure you have access to an email.

When the app starts, select “Register” and you will be prompted to enter your email. Once you’ve entered your email, press “Get Verification Code” and a secure login code will be sent to your email. Enter the code back in the Smart Life App and enter a Password to complete registration.

2. Fireplace WiFi Setup

- To begin WiFi setup, ensure the fireplace is plugged in and receives power. The fireplace will need to be in standby mode (plugged in, flame and heater off). The control buttons are located at the bottom right of the unit.
- Press and hold the Flame button for 5 seconds and release, the Flame Indicator will begin to flash blue, indicating the fireplace is ready to connect to WiFi.
- After Wifi connects, the flame indicator will stay ON until the fireplace is activated.



3. Connect to the Fireplace from the Smart Life App complete registration.

1. In the Smart Life App select “Add Device.” and select “Electric Fireplace”
2. Select the 2.4GHz wireless network option. Enter your Wi-Fi name or allow the App to search for nearby WiFi devices and allow the App to use location services.
3. Reset the Fireplace by pressing and holding the flame button for 5 seconds, then release.
4. A connecting progress screen will show network scanning is active until the device is added successfully. The Kennedy Fireplace control screen will now be active.

4. Check for Firmware Update

Before updating the fireplace’s firmware, please ensure you have a stable internet connection and the fireplace is powered on.

1. In the app, select the device you wish to update.
2. In the device control panel, select the settings icon on the top right, then select “Check for Firmware Update”. You will be prompted to start the update if available.

5. Controls via 4G/LTE Mobile Networks

To control the fireplace with your phone’s mobile network, you will need to connect the fireplace to your home WiFi and have registered for an account in the app. When your fireplace is connected to your home WiFi and your account, you can now have access to your fireplace even if you are not home.



























iOS – Scan the QR code for the Smart Life App in the Apple App Store.

Android - Scan the QR code for the Smart Life App for Google Play.



more help? <https://www.jrhome.com/app-smart-flame-connect-techsup/>

Multi-functional Operating with Remote Control

FUNCTION	ICON	DISPLAY		OPERATION DETAILS
Power		ON		Turn on the fireplace main power
		OF		Turn off the fireplace main power
Flame Group setting		P1		Flame, Ember, ceiling light main power on
		P0		Flame, Ember, ceiling light main power off
Flame	Blue flame 	b4		Brightest blue flame
		b3		Bright blue flame
		b2		Medium blue flame
		b1		Lowest blue flame
		b0		Blue flame off
	Red flame 	r4		Brightest red flame
		r3		Bright red flame
		r2		Medium red flame
		r1		Lowest red flame
		r0		Red flame off
	Yellow flame 	y4		Brightest yellow flame
		y3		Bright yellow flame
		y2		Medium yellow flame
		y1		Lowest yellow flame
		y0		Yellow flame off



























Multi-functional Operating with Remote Control

FUNCTION	ICON	DISPLAY	OPERATION DETAILS	
RGB Flame		F0	F0	RGB flame off
		F1	F1	Red flame
		F2	F2	Orange flame
		F3	F3	Red-Orange flame
		F4	F4	Yellow flame
		F5	F5	Golden flame
		F6	F6	Green flame
		F7	F7	Forest green flame
		F8	F8	Yellow- Green flame
		F9	F9	Blue flame
		FA	FA	Cyan flame
		Fb	Fb	Sea Blue flame
		FC	FC	Light Pink flame
		Fd	Fd	Pink flame
		FE	FE	Bright Pink flame
		FF	FF	Purple flame
Top Light		C0	C0	Top light off
		C1	C1	Red
		C2	C2	Red- Orange
		C3	C3	Light Orange
		C4	C4	Lime
		C5	C5	Green
		C6	C6	Orange
		C7	C7	Blue
		C8	C8	Cyan
		C9	C9	Sea Blue
		CA	CA	Light Purple
		Cb	Cb	Purple
		CC	CC	Pink
		Cd	Cd	Lavender
		CE	CE	Color- rotate
		CF	CF	Rainbow
Ember bed		E0	E0	Ember bed light off
		E1	E1	Red
		E2	E2	Red- Orange
		E3	E3	Light Orange
		E4	E4	Lime
		E5	E5	Green
		E6	E6	Orange
		E7	E7	Blue
		E8	E8	Cyan
		E9	E9	Sea Blue
		EA	EA	Light Purple
		Eb	Eb	Purple
		EC	EC	Pink
		Ed	Ed	Lavender
		EE	EE	Color- rotate
		EF	EF	Rainbow















Multi-functional Operating with Remote Control

FUNCTION	ICON	DISPLAY	OPERATION DETAILS
Heater		H0 	Heater and blower off
		H2 	High heat (1500W)
		H1 	Low heat (750 W)
Child Proof Lock Key	 5 seconds long press	LO 	Heater lock: Press the heater button and hold for 5 seconds, the heater function will be disabled.
Child Proof Unlock Key		UL 	Heater unlocks: the heater lock is on, press the heater button again and hold for 5 seconds, the heater lock function will be disabled.
Temperature		C 	Setting to Celsius degree
		16 	16 Celsius degrees
		19 	19 Celsius degrees
		21 	21 Celsius degrees
		23 	23 Celsius degrees
		25 	25 Celsius degrees
		27 	27 Celsius degrees
		30 	30 Celsius degrees
		F 	Setting to Fahrenheit degree
		61 	61 Fahrenheit degrees
		66 	66 Fahrenheit degrees
		70 	70 Fahrenheit degrees
		73 	73 Fahrenheit degrees
		77 	77 Fahrenheit degrees
		80 	80 Fahrenheit degrees
		86 	86 Fahrenheit degree



Multi-functional Operating with Remote Control

FUNCTION	ICON	DISPLAY		OPERATION DETAILS
Timer		30		30 minutes
		1H		1 hour
		2H		2 hours
		3H		3 hours
		4H		4 hours
		5H		5 hours
		6H		6 hours
		7H		7 hours
		8H		8 hours
		00		OFF
Reset Key		PS		<p>To pre-set the desired flame effect and one button return to the pre-set stage. Press the key for 3 seconds to memorize the flame setting. When you want to return to the pre-set stage, press the key once.</p> <p>Only 1 memorized flame setting saves, so any new setting will override the previous setting.</p>



Remote Control Specification

- 1.Model: R303
- 2.Remote Key: 12
- 3.Communication: Infrared
- 4.Infrared Distance: 6 Meters
- 5.Battery: AAA x 2pcs

NOTE: Make sure your “AAA” batteries (x2) are fully charged and installed correctly in your remote control before operating.

The remote control must remain within 6 meters of the appliance to be effective, this range may be reduced when battery power is depleted.

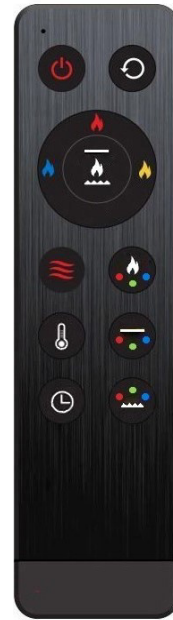

Maintenance

WARNING

PREPARATION FOR MAINTENANCE

ALWAYS DISCONNECT THE POWER AND ALLOW THE ELECTRIC APPLIANCE TO COOL BEFORE PERFORMING ANY CLEANING, MAINTENANCE OR RELOCATION OF THIS ELECTRIC APPLIANCE. TURN CONTROLS TO OFF AND REMOVE PLUG FROM OUTLET OR TURN OFF THE HOUSE CIRCUIT BREAKER TO ELECTRIC APPLIANCE RECEPTACLE.

DO NOT INSTALL LED LIGHT STRIPS THAT EXCEED SPECIFIED MAXIMUM WATTS.

THE LED LIGHT STRIPS IN YOUR APPLIANCE CAN BECOME EXTREMELY HOT. ALLOW AT LEAST 10 MINUTES BETWEEN TURNING OFF THE APPLIANCE AND REMOVING THE STRIPS TO AVOID ACCIDENTAL BURNS.

DO NOT HANDLE THE LED LIGHT STRIPS WITH BARE FINGERS. USE GLOVES OR A CLEAN DRY CLOTH WHEN HANDLING.

Storage Instructions

Ensure the power cord is not installed so that it is pinched or against a sharp edge and ensure that the power cord is stored or secured to avoid tripping or snagging to reduce the risk of fire, electric shock, or injury to persons.

Construction and electrical outlet wiring must comply with local building codes and other applicable regulations to reduce the risk of fire, electrical shock, and injury to persons.

Do not attempt to wire your own new outlets or circuits. To reduce the risk of fire, electric shock, or injury to persons, always use a licensed electrician.

Wiring Diagram: Standard Model



TURN OFF THE APPLIANCE COMPLETELY AND LET COOL BEFORE SERVICING. ONLY A QUALIFIED SERVICE PERSON SHOULD SERVICE AND REPAIR THIS ELECTRIC APPLIANCE.

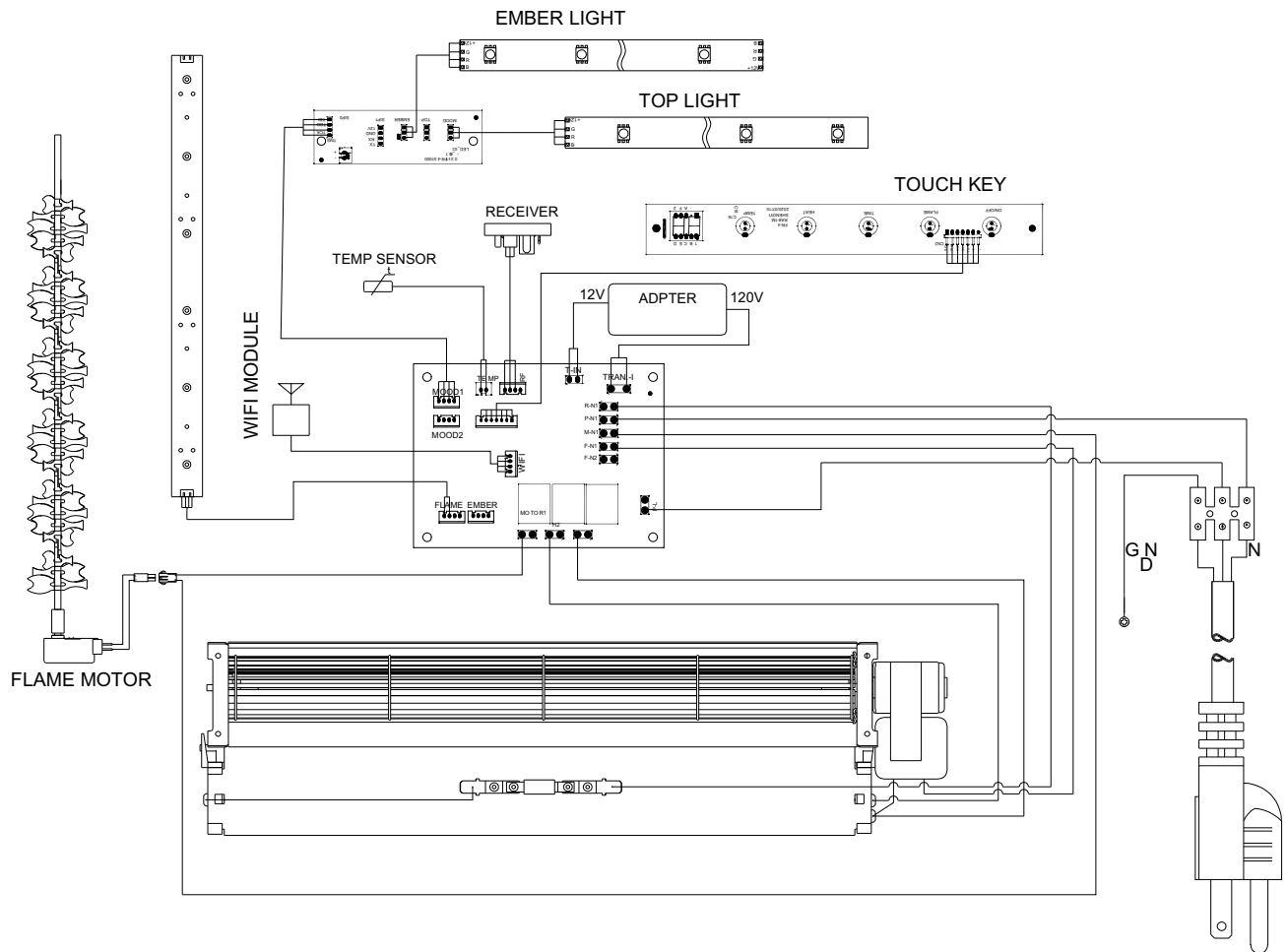

Replacement Parts



WARNING

FAILURE TO POSITION THE PARTS IN ACCORDANCE WITH THIS MANUAL OR FAILURE TO USE ONLY PARTS SPECIFICALLY APPROVED WITH THIS APPLIANCE MAY RESULT IN PROPERTY DAMAGE OR PERSONAL INJURY.

To order parts, contact customercare@jrhome.com

FOR WARRANTY REPLACEMENT PARTS, A PHOTOCOPY OF THE ORIGINAL INVOICE WILL BE REQUIRED TO HONOUR THE CLAIM.

When ordering replacement parts always give the following information:

- Model and serial number of appliance
- Installation date of appliance
- Part reference number
- Description of part
- Finish

FOR FURTHER INFORMATION, CONTACT YOUR AUTHORIZED DEALER.

COMPONENTS

Ref.	Part Description	EF10144	EF10145	EF10146	EF10147
1	Front glass	FG50	FG60	FG72	FG88
2	Flame PP board	PP50	PP60	PP72	PP88
3	Touch panel circuit board	RA8-1M	RA8-1M	RA8-1M	RA8-1M
4	Flame system flicker rod	RB50	RB60	RB72	RB88
5	LED circuit board	FLDXX	FLDXX	FLDXX	FLDXX
6	Main circuit board	DHSJ-LRC29-01-11	DHSJ-LRC29-01-11	DHSJ-LRC29-01-11	DHSJ-LRC29-01-11
7	Heater/Blower system	FRT30-306	FRT30-306	FRT30-306	FRT30-306
8	Flame motor	120v/10/12rpm	120v/10/12rpm	120v/10/12rpm	120v/10/12rpm
9	Power adapter	XY60S-1205000Q-UF	XY60S-1205000Q-UF	XY60S-1205000Q-UF	XY60S-1205000Q-UF
10	Remote control	R303	R303	R303	R303
11	Remote control receiver	301506	301506	301506	301506
12	Crystals	540g	540g	540g	540g
13	Wall mount bracket	324013	324013	328015	328015
14	Log Set	50LOG	60LOG	72LOG	88LOG
15	Hardware Pack	50SCREW	50SCREW	72SCREW	72SCREW

Replacement Parts Diagram



FAILURE TO POSITION THE PARTS IN ACCORDANCE WITH THIS MANUAL OR FAILURE TO USE ONLY PARTS SPECIFICALLY APPROVED WITH THIS APPLIANCE MAY RESULT IN PROPERTY DAMAGE OR PERSONAL INJURY.

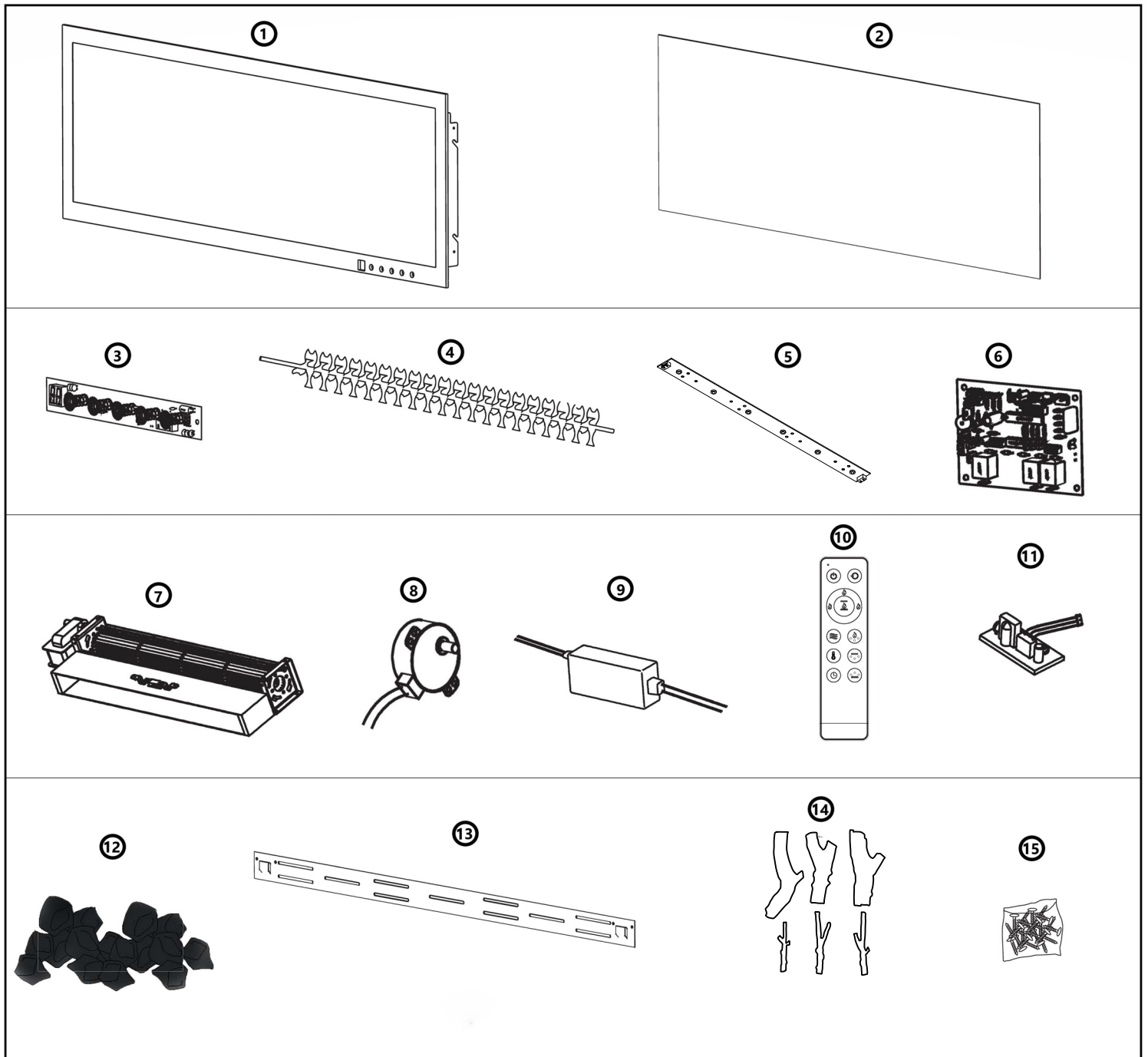

NOTE: Care must be taken when removing and disposing of any broken glass or damaged components. Be sure to vacuum up any broken glass from inside the appliance before operation.

Troubleshooting



TURN OFF THE APPLIANCE COMPLETELY AND LET COOL BEFORE SERVICING. ONLY A QUALIFIED SERVICE PERSON SHOULD SERVICE AND REPAIR THIS ELECTRIC APPLIANCE.

Symptom	Potential Cause	Solution
Abnormal noise	From heater assembly (item 7)	Blower assembly has a defect that is causing noise during high speed rotation. Replace the whole heater assembly
	From flame flicker rod assembly (item 4) a. Repeating clicking sound during flame operation b. Scratching noise during flame operation	Flicker rod (item 4) curved when hitting/ rubbing the flame wall (item 2) and back wall during rotation that cause the noise. If flicker rod is slightly curved, pull out the flame board/flame pattern (which is thin metal) to adjust the depth between the flicker rod and the flame board.
	Noise from flame flicker rod assembly motor.	Lack of lubricant or defect. Replace the motor.
	Internal wiring is losing and fall in between the flicker rod and the back wall that cause the friction noise.	Re-wire and fix the wiring to prevent the wiring from falling.
Heater not blowing	Motor from heater assembly	If motor is not working, the blower doesn't rotate, it will cause the heater overheated. Turn off and unplug the fireplace. Replace the whole heater assembly.
Flame not rotating (e.g. Flame is not moving smoothly or stop moving)	Motor from flame flicker rod system (item 4)	The flame LED is ON, but not rotating. Replace the motor on the flame flicker rod.
Appliance turns off and will not turn on	Appliance has overheated and safety thermal switch has tripped	Unplug power cord and allow appliance to cool for 15 minutes, then plug in the power cord and turn the power ON
	House circuit breaker has tripped	Reset house circuit breaker
The fireplace does not connect to WiFi network	Connection problems between the modem and the fireplace	a) relaunch the application and try again b) turn off/on the fireplace's main power c) reboot the network modem

Troubleshooting

Symptom	Potential Cause	Solution
Dim or no flame / Ember bed / Ceiling light is not glowing or dimming	Flame LED's are burnt out or wire loosing	Inspect the LED's and replace them if necessary
	Ember bed LED's are burnt out or wire loosing	Inspect the LED's and replace them if necessary
	Ceiling Light LED's are burnt out or wire loosing	Inspect the LED's and replace them if necessary
	Main circuit board burnt out or wire loosing	Inspect the Main circuit board and replace if necessary
No warm air coming out of appliance	Room temperature is higher than the appliance setting (if it is set to room temperature)	Reset temperature setting
	Heater is locked out	Unlock heater. See operation section
	Heater is burnt out	Inspect the heater assembly and replace it if necessary
Appliance turns off and will not turn on	Appliance is not plugged into an electrical outlet or the hard wire connections are not correct (if applicable)	Check plug and plug it into a 120V outlet. Check the hard wire connections (if applicable)
	Appliance has overheated and safety thermal switch has tripped	Unplug power cord and allow appliance to cool for 15 minutes, then plug in the power cord and turn the power ON
	Circuit board is burnt out	Inspect the circuit board and replace it if necessary
Remote control does not work	Low battery	Replace batteries in remote control
Heater shuts off automatically	Room is too warm	The heater has a built-in thermostat so it will shut off automatically once the pre-set temperature is reached. It will also turn on automatically if the room temperature drops below the pre-set temperature.
Touch panel/ Remote Control do not work	The front glass has moved or is not secured properly	Unplug the appliance, if the appliance is recessed into the wall, shut off house circuit breaker. Ensure the front glass is in the correct position and is sitting flat to the appliance touch panel. After 10 seconds, plug in or turn on the appliance to reset it.

IMPORTANT

For questions, concerns or problems with our product please email our customer service department:

customercare@jrhome.com

DATED PROOF OF PURCHASE REQUIRED FOR WARRANTY SERVICE

Si vous éprouvez des difficultés, ou si vous avez des questions ou des préoccupations, prière de faire parvenir un courriel à notre Service à la clientèle

customercare@jrhome.com

UNE PREUVE D'ACHAT DATÉE EST REQUISE POUR SE PRÉVALOIR DE LA GARANTIE.

WARRANTY

This product is inspected, tested and carefully packaged to minimize the chance of damage during shipment. If a part (excluding light bulbs, glass and fuses*) within one year from the date of purchase proves to be defective in material or fabrication under normal use, the part will be repaired or replaced. The Company's obligation under the warranty is to replace or repair defective parts at our discretion. Any expenses or damage resulting from the installation, removal or transportation of the product will be the responsibility of the owner and are not covered by this warranty. The owner assumes all other risks arising from the use or misuse of the product. The warranty will be void if the product damage or failure is deemed by the Company to be caused by accident, alteration, misuse, abuse, incorrect installation or removal, or connection to an incorrect power source by the owner. The Company neither assumes, nor authorizes any person or entity to assume for it any obligation or liability associated with its products. Light bulbs and fuses are not covered under this warranty. If you have any questions regarding the warranty or service, please contact us at **customercare@jrhome.com**

Customer Service:

JR Home Products

Unit 306 - 19100 Airport Way, Pitt Meadows, BC V3Y 0E2

Toll Free: 1-800-561-5550

E-mail: **customercare@jrhome.com**

AVERTISSEMENT

Ce produit a été soigneusement inspecté, testé et emballé afin de minimiser les risques de dommages durant le transport. Si l'une des pièces (à l'exception des ampoules électriques verre et des fusibles*) s'avère défectueuse au niveau de sa fabrication ou de ses matériaux dans l'année qui suit la date de l'achat, suite à une utilisation normale, la pièce sera réparée ou remplacée. La Compagnie est tenue de réparer ou remplacer les pièces défectueuses, à sa discrétion, en vertu de la garantie. Tout frais ou dommage résultant de l'installation, du démantèlement ou du transport du produit demeure la responsabilité du client et n'est pas couvert par cette garantie. Le client assume tout autre risque résultant de l'utilisation, correcte ou fautive, du produit. La garantie devient nulle si la Compagnie détermine que le dommage ou le mauvais fonctionnement est causé par un accident, une modification, une mauvaise utilisation, un abus, une mauvaise installation ou un mauvais démantèlement ou un branchement à une source électrique inadéquate de la part du client. La Compagnie n'est pas responsable et n'autorise quiconque, personne ou entité légale, à accepter de responsabilité ou obligation en son nom, en rapport avec ses produits. * Les ampoules électriques et les fusibles ne sont pas couverts par cette garantie. Pour toute question en rapport avec la garantie ou le service, envoyez-nous un courriel à: **customercare@jrhome.com**.

Service à la clientèle :

JR Home Products

Unit 306 - 19100 Airport Way, Pitt Meadows BC V3Y 0E2

Toll Free: 1-800-561-5550

E-mail: **customercare@jrhome.com**

You MUST register your product to receive warranty service.

**Registration can be completed online at
www.jrhome.com or by mailing this form.**

Vous DEVEZ enregistrer votre produit pour vous prévaloir de la garantie.

**L'enregistrement sera complet une fois que vous
aurez posté ce formulaire ou s'inscrire en ligne à:**

Warranty Registration Information Form / Formulaire d'enregistrement de la garantie

Name / Nom: _____
Street / Address: _____
City / Ville: _____
Province / Province: _____
Postal Code / Code postal: _____

Daytime Phone # / No téléphone jour: _____
Evening Phone # / No téléphone soir: _____

E-Mail Address / Courriel: _____

Product/Produit: _____
Place of Purchase / Lieu de l'achat: _____
Date of Purchase / Date de l'achat: _____
Model # / No de modèle: _____
Serial # / Numéro de série: _____

You MUST register your product to receive warranty service.

For warranty service, contact J&R Home Products at the address, phone numbers listed below within 30 days of purchase. Be sure to have your sales receipt and original date of purchase. All warranty service will be coordinated by J&R Home Products service center.

Vous DEVEZ enregistrer votre produit pour vous prévaloir de la garantie.

Afin de faire valoir la garantie, communiquez avec J&R Home Products à l'adresse et aux numéros indiqués ci-dessous dans les 30 jours suivant la date d'achat. Ayez en main votre reçu et la date d'achat. Toutes les demandes liées aux garanties seront traitées par le centre de service de J&R Home Products.