

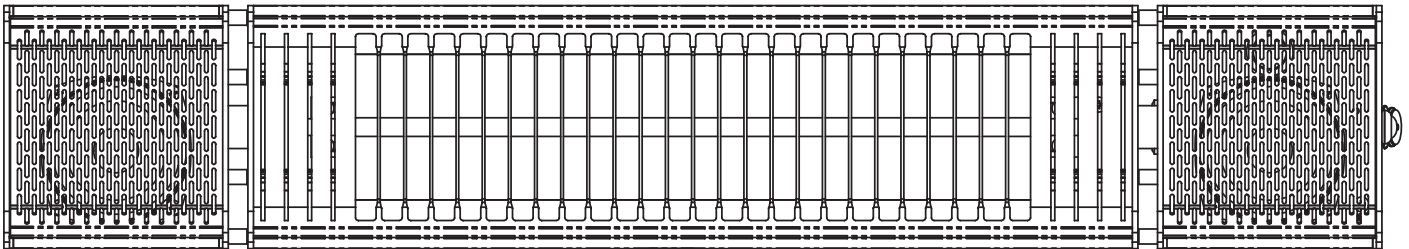

WALL MOUNTED INFRARED PATIO HEATER WITH SPEAKERS

Model #: LDHR062-150KB-S
Item #: PH-100084



READ & SAVE These Instructions

Carefully read and review before attempting to assemble, install, operate or maintain this product. Observe all safety instructions and information. FAILURE TO FOLLOW WARNINGS & OPERATIONAL INSTRUCTIONS CONTAINED IN THIS MANUAL CAN RESULT IN SEVERE PROPERTY DAMAGE AND/OR PERSONAL INJURY.

Do not expose to rain, moisture or flammable materials

*****For Residential Use Only *****



Remote Control Requires
(2) AAA Batteries
(Not Included)



***** Important Notice *****

Do not return to place of purchase!!

Please contact our Toll Free Hotline:

1.800.561.5550

for customer service & warranty issues
e-mail: customercare@jrhome.com

⚠ WARNING

This product can expose you to chemicals including carbon monoxide which is known to the State of California to cause birth defects or other reproductive harm. For more information go to www.P65Warnings.ca.gov.



SAVE THESE INSTRUCTIONS !!

***** Important Notice *****

Do not return to place of purchase!!

Please contact our Toll Free Hotline:

1.800.561.5550

for customer service & warranty issues
e-mail: customer care@jrhome.com



TABLE OF CONTENTS

| | |
|--------------------------------|----------|
| Before You Begin | Page 2 |
| Safety Information | Page 3 |
| Cautions | Page 4 |
| Hardware Contents | Page 4 |
| Important Instructions | Page 5 |
| Remote Control Operations | Page 6 |
| Heater Installation | Page 7-8 |
| Maintenance and Storage | Page 9 |
| Cleaning : Bluetooth Operation | Page 10 |
| Halogen Bulb Replacement | Page 11 |
| Troubleshooting | Page 12 |
| Warranty Information | Page 13 |



BEFORE YOU BEGIN

Please read and understand this entire manual before attempting to assemble, operate or install this appliance. If you have any questions regarding the product, please contact the retailer.

This manual contains important information about the assembly, operation and maintenance of this LPG Patio Heater. General safety information is presented in the first few pages and is also located throughout this manual. Keep this manual for future reference and to educate new users of this appliance.



NOTE: Electronic ignition. Requires 2 (AAA) battery.
(Not Included)

***** Important Notice *****

Do not return to place of purchase!!

Please contact our Toll Free Hotline:
1.800.561.5550
for customer service & warranty issues
e-mail: customercare@jrhome.com



Safety Guidelines

Read this manual carefully for guidance on the assembly and use of this product.

DANGER

Indicates a potentially hazardous situation which, if not avoided, WILL result in serious injury or death.

WARNING

Indicates a potentially hazardous situation, if not avoided, COULD result in serious injury or death.

CAUTION

Indicates a potentially hazardous situation which, if not avoided, MAY cause moderate injury or damage to the equipment.

NOTICE:

Indicated important information that if not followed, may cause damage to the equipment.

DANGER

1



Risk of Fire. There is always a risk of fire when working with a heater. Keep heater away from flammable liquids and materials.



2. **Risk of Fire.** Follow instructions above and also for further prevention keep this unit at least 3 feet (.9m) away from everything.



3. **Hot or Burn Hazard.** This unit may be extremely hot while in use. Careful when handling especially around the head of the unit.



4. **Electrical Hazard.** Disconnect from electrical outlet before working on the unit to avoid chance of electrical shock.



5. **Electric Shock.** Do not use near water. Do not use if cord has been damaged.

CAUTION

- Improper treatment of the heater can damage it and also shorten its life span.
- To prevent electrical shock, ensure electrical plug is properly inserted into the electrical outlet.
- Unit is hot when operating. Keep at least 3' away from everything. Do not place any objects such as furniture, papers, clothing or curtains closer than 3' to the front and sides of the heater

***** Important Notice *****

Do not return to place of purchase!!

Please contact our Toll Free Hotline:
1.800.561.5550
for customer service & warranty issues
e-mail: customercare@jrhome.com

**Recommended Primarily For
Sheltered EXTERNAL use
Do NOT expose to
rain or moisture**



PRODUCT COMPONENTS AND PARTS LIST

This appliance MUST be grounded.

- * When using outdoors, we recommend using a certified GFI (Ground Fault Interrupt) outlet to protect against electrical shock.
- * Ensure that the heater mounting bracket is SECURELY fastened to the wall, patio overhang or house eave.
- * Route electrical cable AWAY from main body of heater which gets very hot.
- * Do NOT cover or obstruct the main body of the heater during use.
- * All Installations must be in accordance with I.E.E. safety regulations or equivalent. If you are unsure, consult an electrical service professional.
- * Avoid the use of an extension cord with this appliance.
- * Do not place any objects such as furniture, papers, clothing or curtains closer than 3 ft to the front and sides of the heater.



NOTE: your IR Heater main body, electrical components & bracket are fully factory assembled. Do NOT attempt to service or disassemble without proper instructions.

PARTS LIST

1 Remote (1)

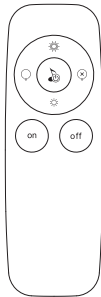

2 L-Bracket (1)

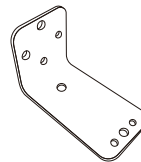

3 Wing nuts (2)

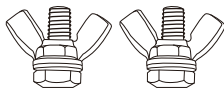

4 Concrete anchors (3)

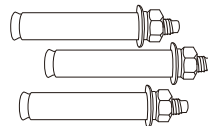

5 Wrench(1)



**Remote Control
Requires (2) AAA Batteries
(Not Included)**



***** Important Notice *****

Do not return to place of purchase!!

Please contact our Toll Free Hotline:

1.800.561.5550

for customer service & warranty issues

e-mail: customer@jrhome.com



Important Instructions

1. Read all instructions before using this heater.
2. This heater will get very hot while in use. To avoid burning, do not let bare skin touch hot surfaces. If provided, use handles when moving this heater. Keep flammable materials, such as furniture, pillows, bedding, papers cloths, and curtains at least 3 feet (0.9m) from the heater.
3. **DO NOT LEAVE** heater unattended. Extreme caution is necessary when any heater is used by, or near, children or disabled persons, and whenever the heater is left operating and unattended
4. Always unplug heater when not in use.
5. Do not operate any heater with a damaged cord or plug, if the heater malfunctions, or has been dropped or damaged in any manner. Return heater to authorized service facility for repairs.
6. Can be used indoors or outdoors, operate 3 feet (0.9m) from people or objects.
7. Never operate heater near water or where it can be knocked over.
8. Do not run cord under carpeting. Do not cover cord with throw rugs, runners, or similar coverings. Arrange cord away from traffic area and where it will not be tripped over.
9. To disconnect heater, remove plug from electrical outlet.
10. Connect to properly grounded outlets only.
11. Do not insert or allow foreign objects to enter ventilation or exhaust opening; doing so may cause an electrical shock or fire, or may damage the heater.
12. To prevent a possible fire, do not block air intakes or exhaust in any manner. Do not use on soft surfaces, like a bed, where openings may become blocked.
13. A heater has hot and sparking parts inside. Do not use it in areas where gasoline, paint, or flammable liquids are used or stored.
14. Use this heater only as described in this manual. Any other use not recommended by the manufacturer may cause fire, electrical shock, or injury to persons.
15. Avoid the use of an extension cord because the extension cord may overheat and cause a risk of fire. However, if you have to use an extension cord, use either a 12 or 14 gauge wire which is rated not less than 1900 watts. The recommended length for a 14 gauge is 0-50 feet, but if need be long use a 12 gauge no longer than 100 feet.
16. **SAVE THESE INSTRUCTIONS** for future reference.

***** Important Notice *****

Do not return to place of purchase!!

Please contact our Toll Free Hotline:
1.800.561.5550
 for customer service & warranty issues

REMOTE CONTROL INSTRUCTIONS



Remote Control
 Requires (2) AAA Batteries
 (Not Included)



| Button | Graphic | Feature |
|-----------------|---------|---|
| Higher Heat | | Up one heating level |
| Lower Heat | | Down one heating level |
| LED Light On | | Turns on the LED Light |
| LED Light Off | | Turns off the LED Light |
| On | | To switch the heater on: Press ON. The patio heater has a soft start function of 33% power. 4 seconds after the heater has been turned on, it will automatically switch to the last heating level used. In case of the first-time use, after 4 seconds the heater will automatically switch to 100% power. |
| Off | | To switch the heater off: Press OFF. The heater will switch to standby mode(the receiver indicator will light up). |
| Speaker Control | | Turn on/off the speaker Short press,turn on/off the speaker. Long press,enter into bluetooth pairing mode. |

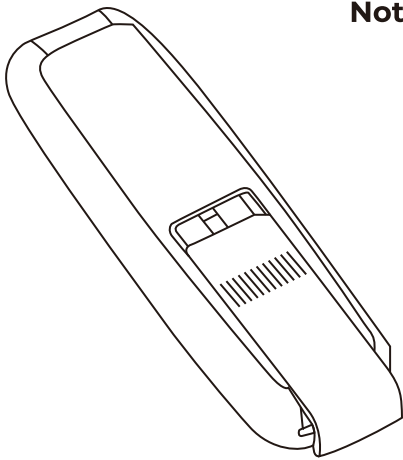
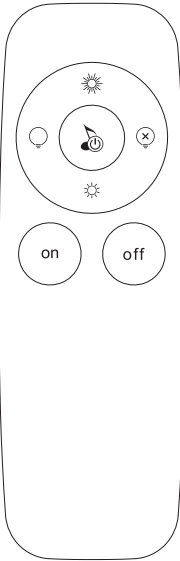

- Notice:**
- ▶ Use 2 pieces AAA size 1.5V batteries in the remote control.
 - ▶ Remove the battery when not in use for a long time, thus the lifespan of remote control can be extended.
 - ▶ Choose the same specification battery when replacing the battery inside, otherwise it may cause remote control not work , thereby affect the normal use of the heater.
 - ▶ The remote control function may be out of work if there is a barrier between the remote control and heater .
 - ▶ Replacing the batteries duly so as not to affect the normal use of heater and remote control.

REMOTE CONTROL DISTANCE

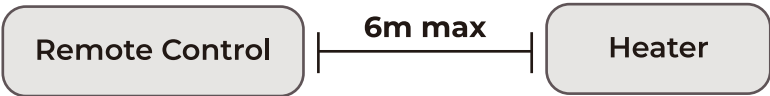

***** Important Notice *****

Do not return to place of purchase!!

Please contact our Toll Free Hotline:

1.800.561.5550

for customer service & warranty issues
e-mail: customer care@jrhome.com

OPERATING INSTRUCTIONS



- Remove all package material (including anti-vibration object of the lamp) and check the appliance, supply cord and the plug for signs of damage. (if damage is found, stop use and contact supplier immediately)
- Pay attention to the mounting place and all mounting material (dowels, screws). Ensure they are suitable and stable enough for mounting and lastingly holding of the appliance.
- Before mounting, the minimum safe mounting distances and tilt angles shown in the figures must be strictly followed.
- Mounting bracket and anchor dowels provided. Connection from the wall to the infrared heater.

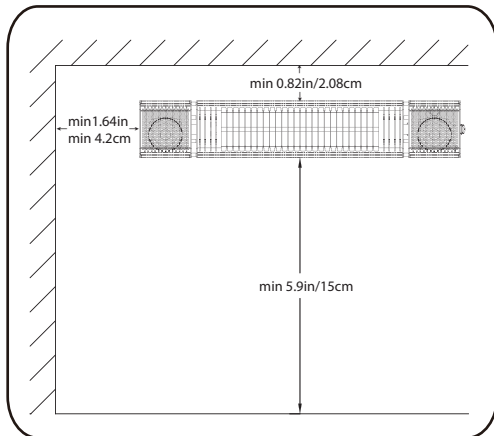
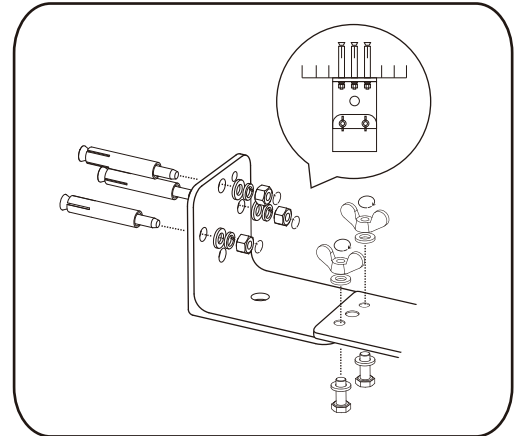

- The distance between the bottom edge of the appliance and the floor must be at least 6 feet/183cm.
- There must be a distance of at least 8 inches/20.3cm between the appliance and the ceilings, roofs or other covers.
- There must be a distance of at least 18 inches/45.7cm at each side between the appliance and walls or the like.

RECOMMENDED MOUNTING ANGLE (45 DEGREES)

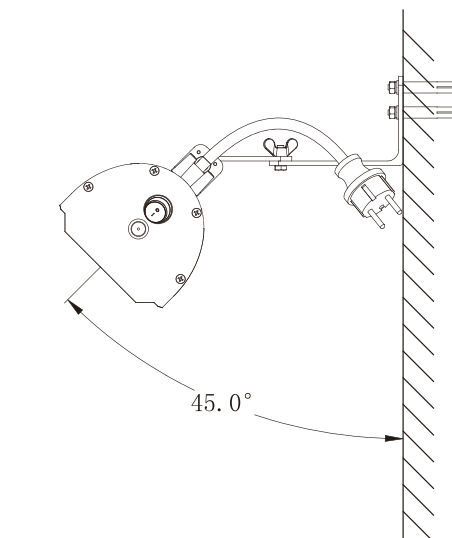

***** Important Notice *****

Do not return to place of purchase!!

Please contact our Toll Free Hotline:

1.800.561.5550

for customer service & warranty issues
e-mail: customercare@jrhome.com

HEATER INSTALLATION



WALL MOUNT

Step 1

Place L-Bracket (c) on the wall positioned over drilled holes. For concrete walls, use Concrete Anchors (f). For wood walls, use Wood Screws (a). Fasten anchors/screws lightly apply weight to be sure it is secure.

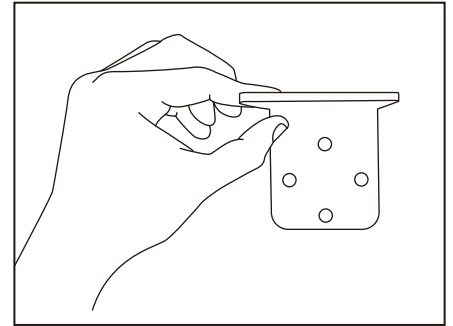

Step 2

Place heater on L-Bracket (c) and fasten heater using Wing Nuts (e) as shown above. Once fastened securely, adjust angle of heater to preferred angle for best heat optimization. (Recommended 45 degrees)

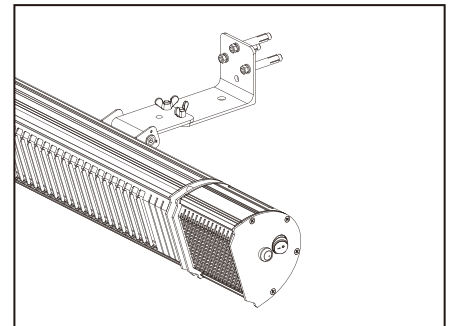

Step 3

Once the heater is securely mounted, switch the unit on. To verify power is coming to the unit, look for a blue LED light located on the front/right of heater.

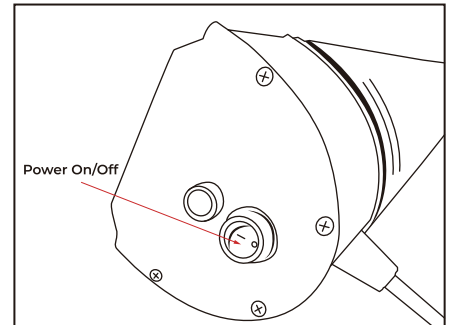

Step 4

Check all functions work with the remote control. Download the Sunkare Heater app and install to control bluetooth functions (see page 10 and the included App Guide)

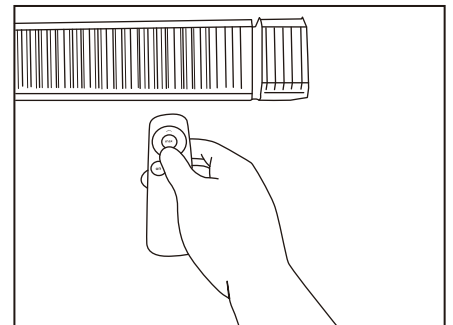

***** Important Notice *****



Do not return to place of purchase!!

Please contact our Toll Free Hotline:

1.800.561.5550

for customer service & warranty issues
e-mail: customercare@jrhome.com

MAINTENANCE & STORAGE



This appliance MUST be grounded.

- * When using outdoors, we recommend using a certified GFI (Ground Fault Interrupt) outlet to protect against electrical shock.
- * Ensure that the heater mounting bracket is **SECURELY** fastened to the wall, patio overhang or house eave.
- * Route electrical cable **AWAY** from main body of heater which gets very hot.
- * Do **NOT** cover or obstruct the main body of the heater during use.
- * All Installations must be in accordance with I.E.E. safety regulations or equivalent. If you are unsure, consult an electrical service professional.
- * Avoid the use of an extension cord with this appliance. If one is used, **it MUST be at least a 14/3 wire, grounded cord, 50ft max. length.**

- * **Do not place any objects such as furniture, papers, clothing or curtains closer than 3 ft to the front and sides of the heater.**

NOTE: your IR Heater main body, electrical components & bracket comes fully factory assembled. Do **NOT** attempt repair or disassembly, contact our toll free customer service hotline for assistance.



For optimal performance and safety concerns, we HIGHLY RECOMMEND that the Infrared Heater Head be operated at a min. of 84" ht. /213.4cm with a 45-55 degree angle of operational spread.

Specifications

| | |
|-----------------------------|---|
| Model: | LDHR062-150KB-S |
| Voltage: | 120 volts |
| Amps: | 12.5 amps |
| Wattage: | 1500 watts |
| Lamp Type: | Quartz Halogen |
| IP protection: | IP65 |
| Infrared receiving Angle | 60° ± 5° |
| Min. Operational Height: | 72" (6 ft.)/ 183cm |
| Weight: | 8.4 lbs./3.81kg |
| Head Unit Dimensions: | 29.0" x 5.1" x 4.3"/73.66cm x 13cm x 10.9cm |
| Bluetooth receiver distance | ≤ 20M |
| The speaker power | 3W × 2 |

Storage

Always UNPLUG unit when not in use!

- * The IR Head unit can be left outside during the season as long as it is mounted under a covered, protected location.
 - During expected moderate weather conditions, we recommend wrapping the head unit with a poly bag and tape or a bungee cord. For extreme weather conditions, it is recommended that you remove the unit from the wall bracket and store in a safe, dry indoor location.

- * When not in use for extended periods of time, the IR Head Unit can be easily removed from the wall mounting bracket for storage indoors.
 - **The halogen lamp is fragile, be careful not to hit or jar the head unit.**
 - Store in a dry location placing the head unit on a soft cushioned surface.
 - Make sure the electrical cord is properly coiled and out of the way.

***** Important Notice *****

Do not return to place of purchase!!

Please contact our Toll Free Hotline:

1.800.561.5550

for customer service & warranty issues
e-mail: customercare@jrhome.com

CLEANING and BLUETOOTH OPERATION



Cleaning

Your infrared heater has been designed so that the robust housing does not require any maintenance, only cleaning as may occasionally be required.

- Switch off and unplug the heater before cleaning it.
- Only clean it when it is cool.
- When cleaning, use a microfibre cloth and avoid using aggressive cleaning agents, scouring sponges or stiff brushes.
- Do not use flammable cleaning agents.
- Once you have cleaned the heater, allow it to dry before switching it on again.

Bluetooth Operation

A free Bluetooth App is available to download for this heater for either your iPhone, iPad or Android device.

The 'Sunkare Heater' App will allow you to connect remotely to many heaters and control them independently. Control functions include:

- Speaker control
- On/Off
- Variable heat output from 25% to 100%
- Timer with auto shut off
- Password connection to heaters
- Individual heater identification and control

***** Important Notice *****

Do not return to place of purchase!!

Please contact our Toll Free Hotline:

1.800.561.5550

for customer service & warranty issues
e-mail: customer care@jrhome.com

HALOGEN BULB REPLACEMENT



NOTE: do NOT touch the new halogen lamp with your bare fingers. Oils from your hand could reduce the life of the lamp by causing a heat spot. Recommend using clean cotton or plastic gloves. A clean paper towel may also work.



Step 1

Make sure all power is shut off to your heater from the main power supply. Failure to disconnect heater before replacing the emitter could cause bodily harm or death. Be sure that the heater and element(s) are cool and not hot. Failure to do so could result in burns.

**Make sure heater is
DISCONNECTED
from electrical outlet
BEFORE beginning**

Step 2

Remove screws from both sides of the heater. (Keep all parts in a safe area) Once the screws and aluminum caps have been removed, carefully slide the protective grill out exposing the heating element and plastic IP65 sealing connectors as shown below:

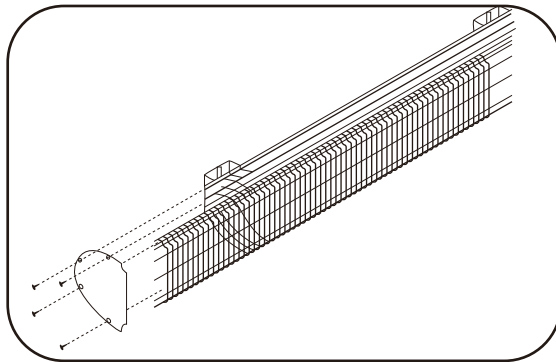

**Use ONLY approved,
original equipment
replacement quartz
halogen lamps to insure
safe, proper and maxi-
mum output operation of
your infrared heater!**

Step 3

Carefully unscrew the plastic IP65 sealing connectors and carefully slide the cap back to expose the wiring and metal connector system. Disconnect the metal locking system by pressing the safety lock tab in. Once you have released the heating element you will then remove the small reflector shields that secure the element(s) in. Once you have removed the heating element(s), you will then slide the new element(s) in and fasten them back in securely as you took them out.

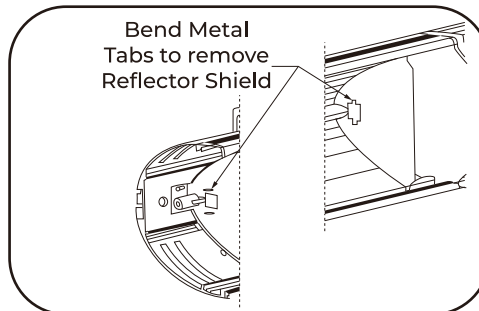
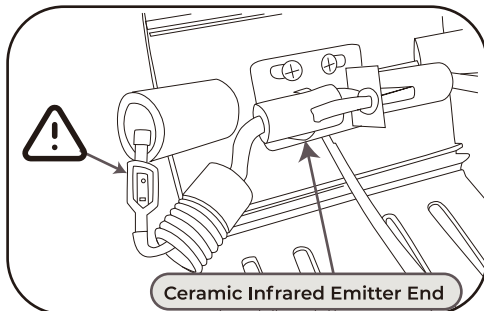

***** Important Notice *****

Do not return to place of purchase!!

Please contact our Toll Free Hotline:

1.800.561.5550

for customer service & warranty issues
e-mail: customercare@jrhome.com



TROUBLESHOOTING

| Problem | Solution |
|---|--|
| Unit fails to turn on. | Check electrical plug connection at wall outlet for complete, snug fit. Check GFI circuit, reset breaker if necessary Possibly connected to wall switch that is in off position Damaged halogen lamp, call customer service hotline |
| Head unit is loose or unsteady Head unit is hard to adjust | Tighten connecting bolts/nuts at swivel bracket Loosen connecting bolts/nuts at swivel bracket |
| Smoke appears from head unit | Unplug IMMEDIATELY & call customer service hotline |
| Weak light output from halogen lamp | Life span of lamp has been reached or damaged lamp Call customer service hotline for assistance. |

IMPORTANT

For questions, concerns or problems with our product please email our customer service department:

customercare@jrhome.com

DATED PROOF OF PURCHASE REQUIRED FOR WARRANTY SERVICE

Si vous éprouvez des difficultés ou si vous avez des questions ou des préoccupations, prière de faire parvenir un courriel à notre service à la clientèle

customercare@jrhome.com

UNE PREUVE D'ACHAT DATÉE EST REQUISE POUR SE PRÉVALOIR DE LA GARANTIE.

WARRANTY

This product is inspected, tested and carefully packaged to minimize the chance of damage during shipment. If a part (excluding light bulbs, glass and fuses*) within one year from the date of purchase proves to be defective in material or fabrication under normal use, the part will be repaired or replaced. The Company's obligation under the warranty is to replace or repair defective parts at our discretion. Any expenses or damage resulting from the installation, removal or transportation of the product will be the responsibility of the owner and are not covered by this warranty. The owner assumes all other risks arising from the use or misuse of the product. The warranty will be void if the product damage or failure is deemed by the Company to be caused by accident, alteration, misuse, abuse, incorrect installation or removal, or connection to an incorrect power source by the owner. The Company neither assumes, nor authorizes any person or entity to assume for it any obligation or liability associated with its products. Light bulbs and fuses are not covered under this warranty. If you have any questions regarding the warranty or service, please contact us at **customercare@jrhome.com**.

Customer Service :

JR Home Products

Unit 306 - 19100 Airport Way, Pitt Meadows, BC V3Y 0E2

Toll Free : 1-800-561-5550

E-mail : **customercare@jrhome.com**

AVERTISSEMENT

Ce produit a été soigneusement inspecté, testé et emballé afin de minimiser les risques de dommages durant le transport. Si l'une des pièces (à l'exception des verres, des ampoules électriques et des fusibles*) s'avère défectueuse au niveau de sa fabrication ou de ses matériaux dans l'année qui suit la date de l'achat suite à une utilisation normale, la pièce sera réparée ou remplacée. La compagnie est tenue de réparer ou remplacer les pièces défectueuses à sa discrétion, en vertu de la garantie. Tous frais ou dommage résultant de l'installation, du démantèlement ou du transport du produit demeurent la responsabilité du client et n'est pas couvert par cette garantie. Le client assume tout autre risque résultant de l'utilisation correcte ou fautive du produit. La garantie devient nulle si la compagnie détermine que le dommage ou le mauvais fonctionnement est causé par un accident, une modification, une mauvaise utilisation, un abus, une mauvaise installation ou un mauvais démantèlement ou un branchement à une source électrique inadéquate de la part du client. La compagnie n'est pas responsable et n'autorise quiconque, personne ou entité légale, à accepter de responsabilité ou obligation en son nom, en rapport avec ses produits. * Les ampoules électriques et les fusibles ne sont pas couverts par cette garantie. Pour toute question au sujet de la garantie ou du service, contacter le service à la clientèle à : **customercare@jrhome.com**.

Service à la clientèle:

JR Home Products

Unit 306 - 19100 Airport Way, Pitt Meadows BC V3Y 0E2 Numéro

sans frais: 1-800-561-5550

Courriel: **customercare@jrhome.com**

You MUST register your product within 30 days of purchase to receive warranty service.

Registration can be completed online at www.jrhome.com or by mailing this form.

Vous DEVEZ enregistrer votre produit dans les 30 jours suivant l'achat pour bénéficier du service de garantie.

L'enregistrement sera complet une fois que vous aurez posté ce formulaire ou que vous serez inscrit en ligne.

Warranty Registration Information Form / Formulaire d'enregistrement de la garantie

Name / Nom : _____

Street / Adresse : _____

City / Ville : _____

Province / Province : _____

Postal Code / Code postal : _____

Daytime Phone # / No téléphone jour : _____

Evening Phone # / No téléphone soir : _____

E-Mail Address / Courriel : _____

Product/Produit : _____

Place of Purchase / Lieu de l'achat : _____

Date of Purchase / Date de l'achat : _____

Model # / No de modèle : _____

Serial # / Numéro de série : _____

You MUST register your product to receive warranty service.

For warranty service, contact J&R Home Products at the address, phone numbers listed below within 30 days of purchase. Be sure to have your sales receipt and original date of purchase. All warranty service will be coordinated by J&R Home Products service center.

Vous DEVEZ enregistrer votre produit pour vous prévaloir de la garantie.

Afin de faire valoir la garantie, communiquez avec J&R Home Products à l'adresse et aux numéros indiqués ci-dessous dans les 30 jours suivant la date d'achat. Ayez en main votre reçu et la date d'achat. Toutes les demandes liées aux garanties seront traitées par le centre de service de J&R Home Products.

